

Ethereum



Yann Vonlanthen

Research Scientist, Ethereum Foundation

This lecture is based in part on slides graciously made available by Julian Ma, Lucianna Kiffer, Parithosh Jayanth, and Roberto Saltini.



Disclaimers

About me

- Working as a Research Scientist at the Ethereum Foundation.
 - Consensus Research
 - Team works to *improve the Ethereum protocol*.
 - The rules that participants follow.
 - Examples:
 - More throughput
 - Lower latency
 - Better security
 - Importantly, the Ethereum Foundation does not control Ethereum.
- Working on my PhD at ETH Zurich
 - blockchain / distributed systems / digital democracy

Feel free to reach out to me if you have any questions!

Section 1

Overview



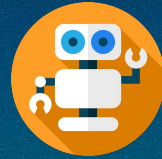



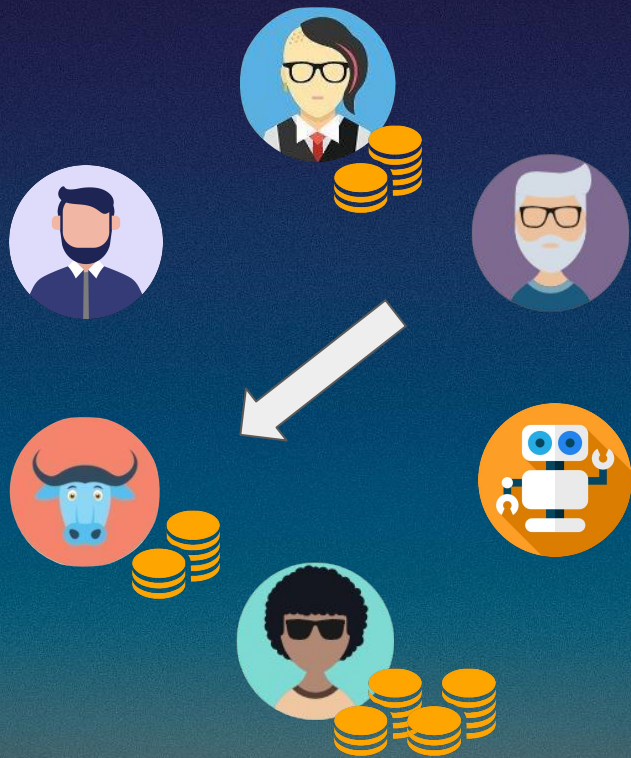

Digital Property Rights

Blockchains record who owns what.

Only **~valid~** transactions can be processed = cannot double-spend.

Storage on a computer with an operator or owner does not have this!

If I send you 1 ETH on Ethereum, it means something.

If I send you 1 ETH on my laptop's storage, it means nothing.

This creates **🌟 Digital Scarcity 🌟**

Example: At most, there will be 21 million bitcoin.



Public Ledger

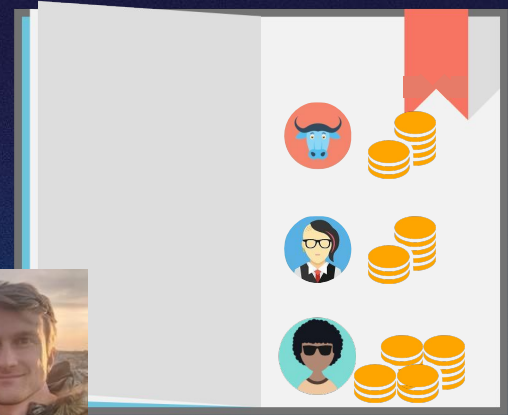

Public Ledger



Distributed Ledger

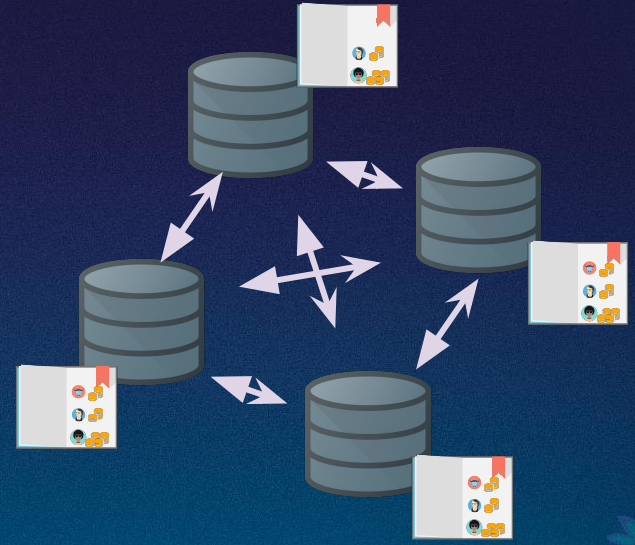

How can nodes agree on the state of the ledger?

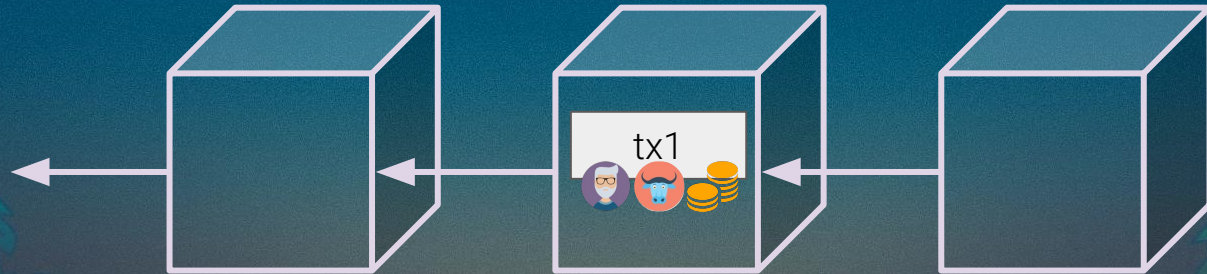
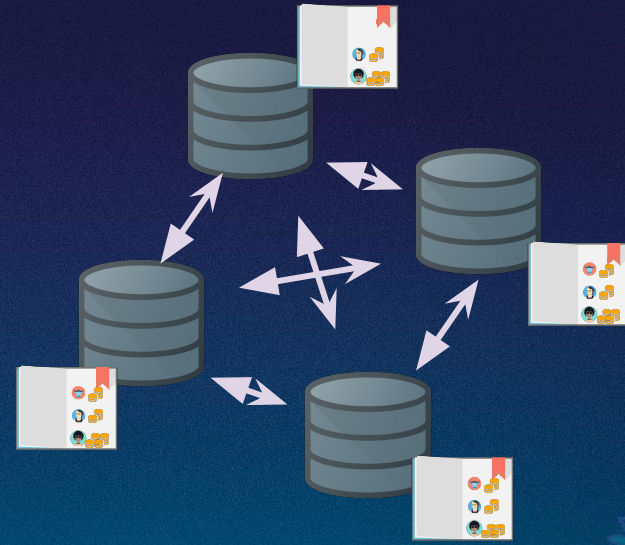

Blockchain

High-level Overview

Every 12 seconds, a new Ethereum block is added to the chain.

Each block:

- Builds on a previous block.
- Contains transactions (transfers, swaps, messages).
- Contains other information too, for example **~consensus information~**

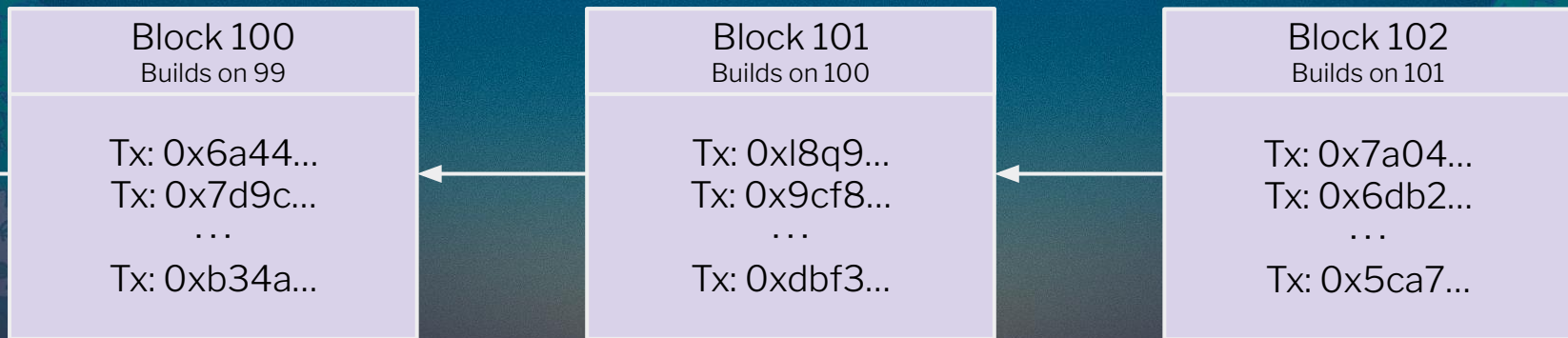

High-level Overview

Application Layer

Ethereum Virtual Machine (EVM)

Consensus Layer

Proof-of-Stake (LMD-GHOST & Casper FFG)

Networking Layer

Peer-to-Peer (libp2p, discv4/5, ...)



High-level Overview

Application Layer

Ethereum Virtual Machine (EVM)

Consensus Layer

Proof-of-Stake (LMD-GHOST & Casper FFG)

Networking Layer

Peer-to-Peer (libp2p, discv4/5, ...)

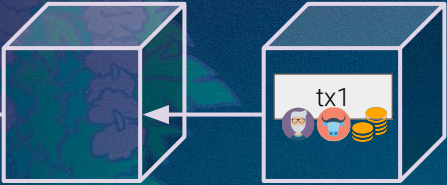
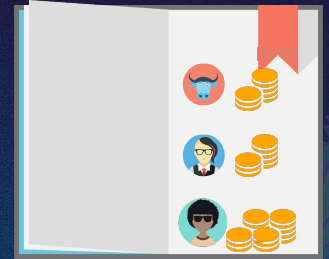

High-level Overview

Application Layer

Ethereum Virtual Machine (EVM)

Consensus Layer

Proof-of-Stake (LMD-GHOST & Casper FFG)

Networking Layer

Peer-to-Peer (libp2p, discv4/5, ...)

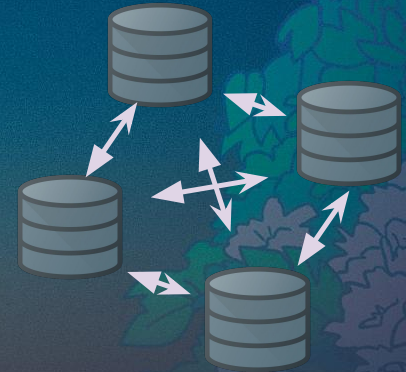
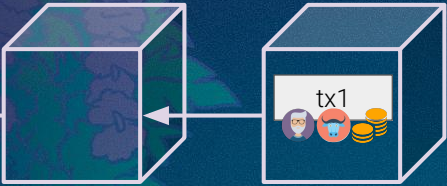
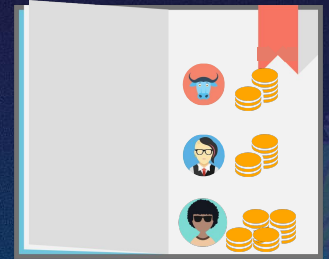



Section 1

Consensus Layer



High-level Overview



Application Layer:
Ethereum Virtual Machine (EVM)

Consensus Layer:
Proof-of-Stake (LMD-GHOST & Casper FFG)

Networking Layer:
Peer-to-Peer (libp2p, discv4/5, ...)

Overview

Thousands of computers run the Ethereum software worldwide.

- To make progress, computers need to agree on what state transitions should be performed.
- This is the role of the consensus protocol.

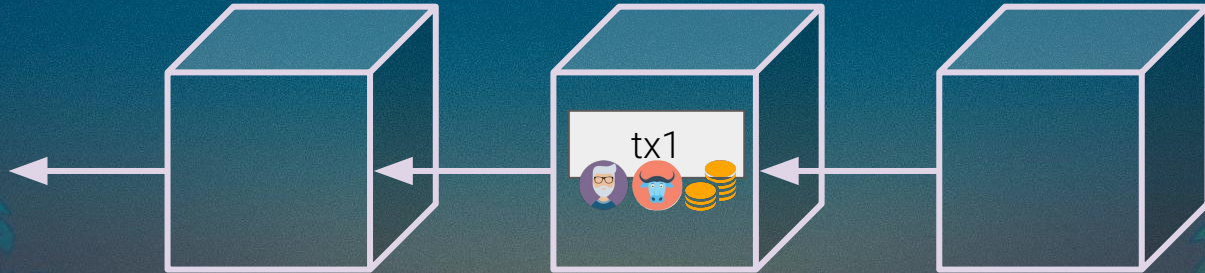

Section 1.1

Proof-of-Work

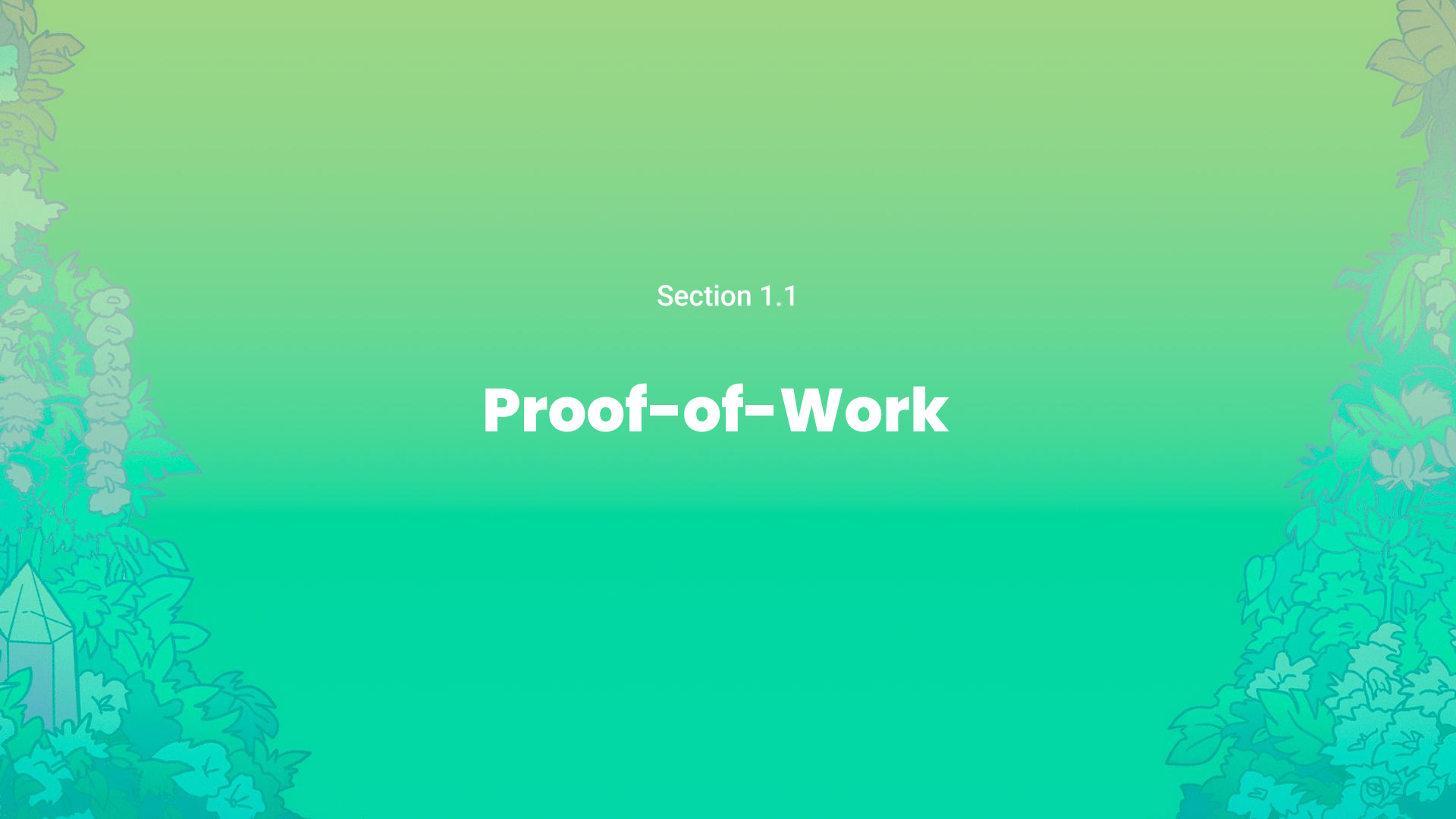

A Short Proof-of-Work Primer

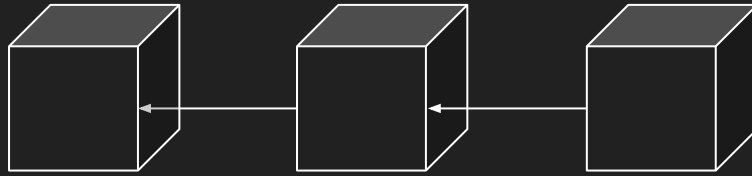

A Short Proof-of-Work Primer

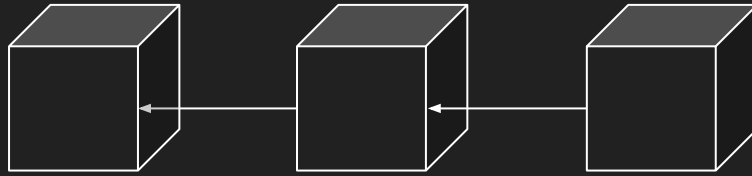

A Short Proof-of-Work Primer

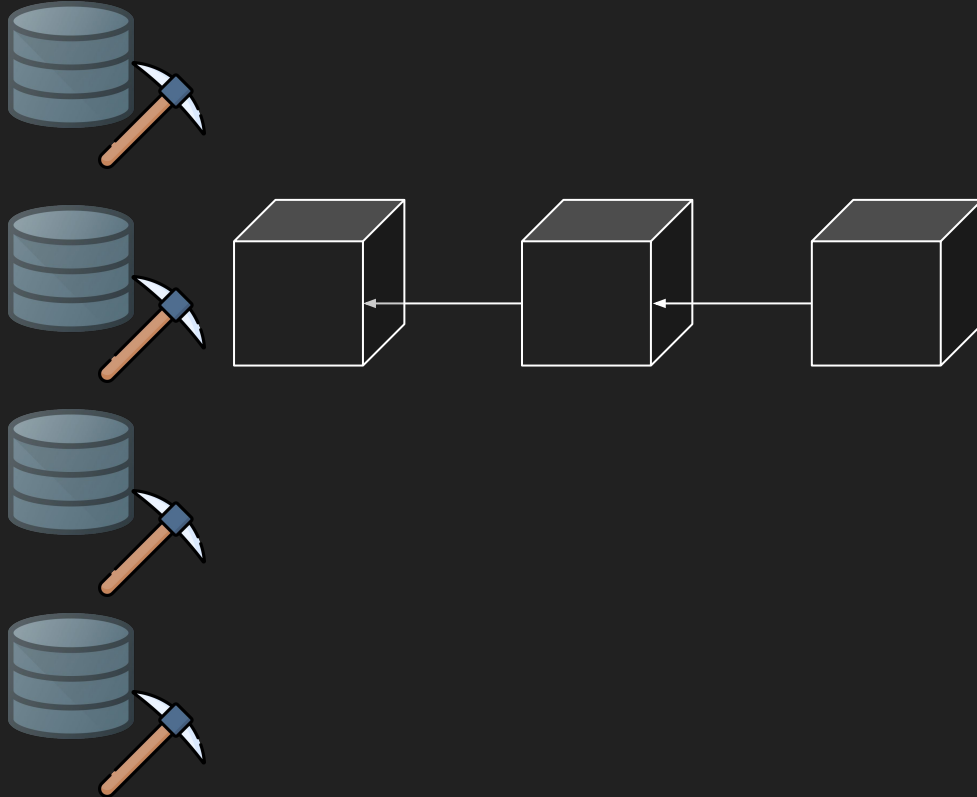

A Short Proof-of-Work Primer

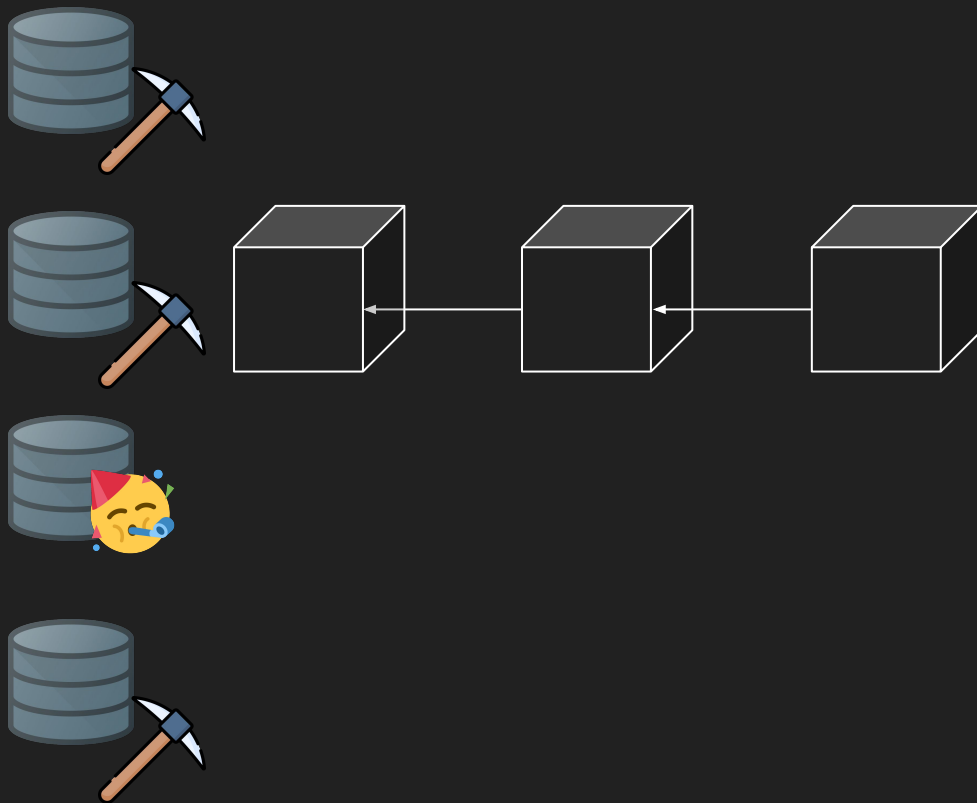

A Short Proof-of-Work Primer

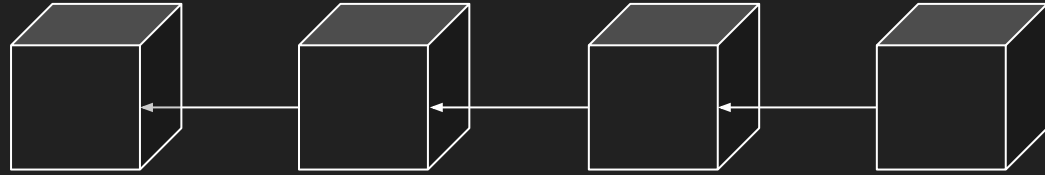

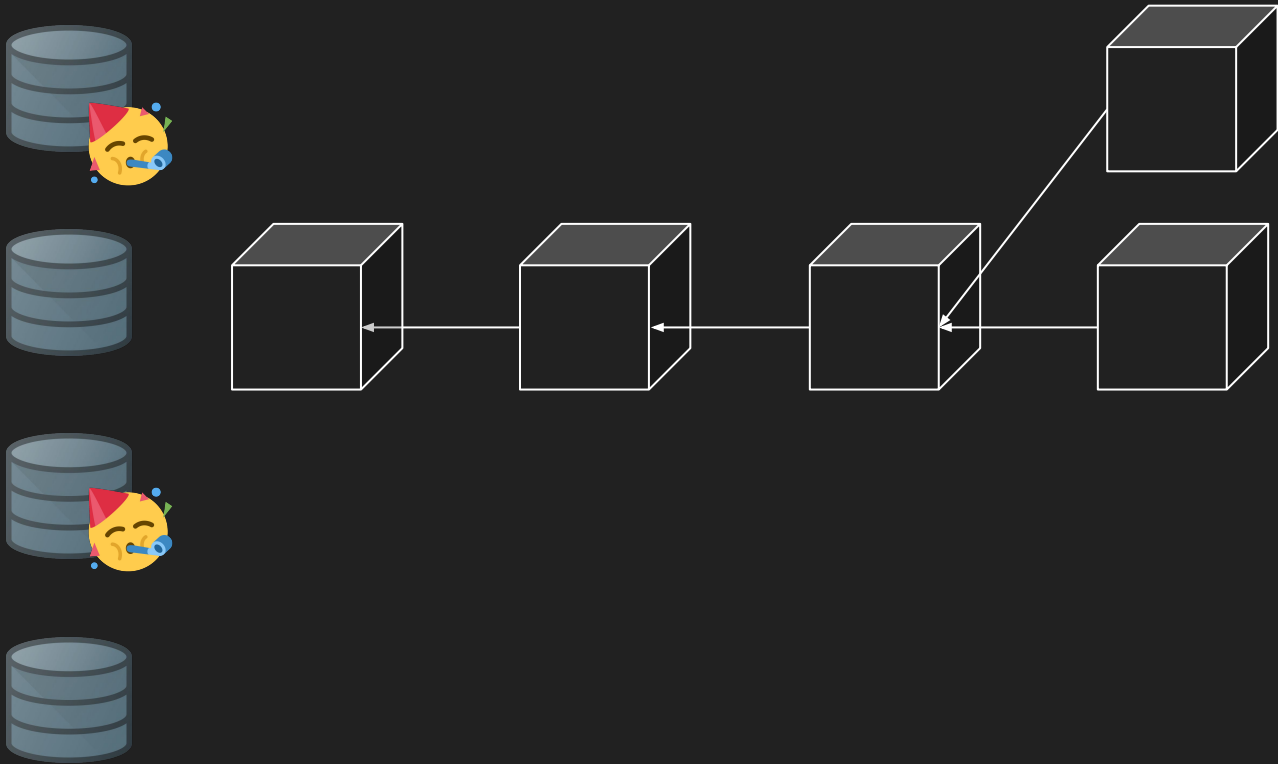

Forks

Changing consensus
rules

→ **hard fork**

Famous examples:

- The DAO
- The Merge
- Pectra

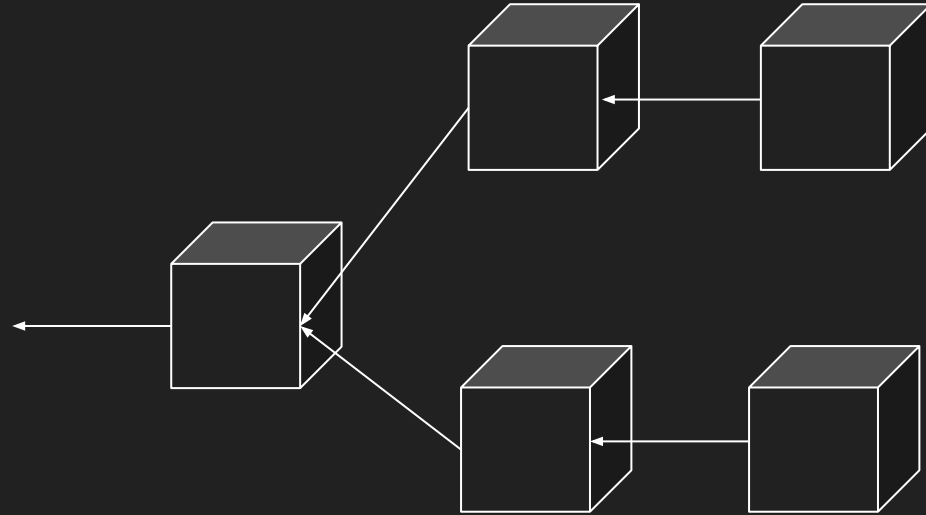

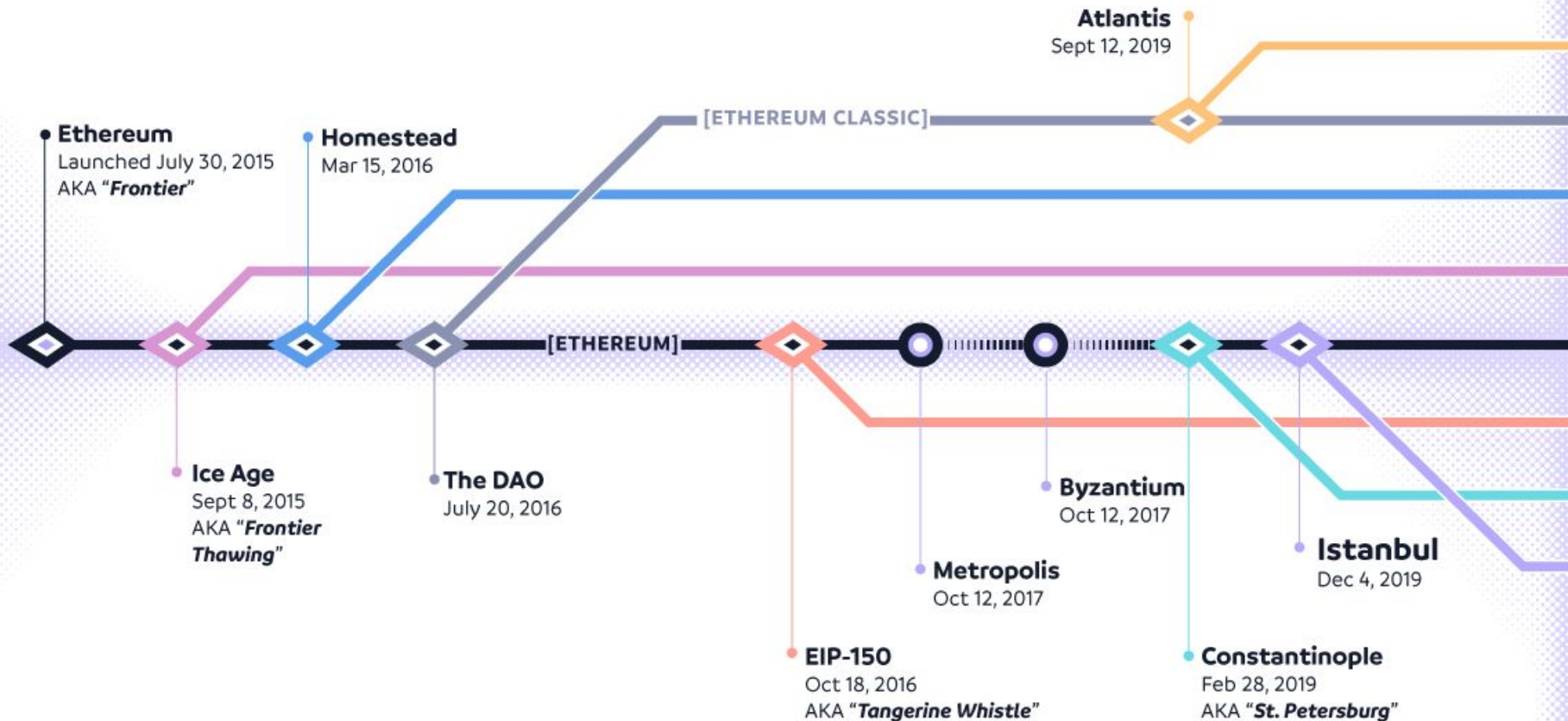

Mining Algorithms



$$\mathcal{F}_d(c, x) \rightarrow \{true, false\}$$

c: challenge

x: nonce

d: difficulty

Mining Algorithms



$$\mathcal{F}_d(c, x) \rightarrow \text{SHA256}(\text{SHA256}(c|x)) < \frac{2^{224}}{d}$$

c: challenge

x: nonce

d: difficulty

Mining Algorithms



$$\mathcal{F}_d(c, x) \rightarrow \text{SHA256}(\text{SHA256}(c|x)) < \frac{2^{224}}{d}$$

c: challenge
x: nonce
d: difficulty

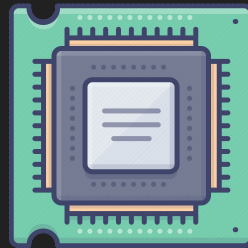

Mining Algorithms



$$\mathcal{F}_d(c, x) \rightarrow \text{SHA256}(\text{SHA256}(c|x)) < \frac{2^{224}}{d}$$

c: challenge
x: nonce
d: difficulty

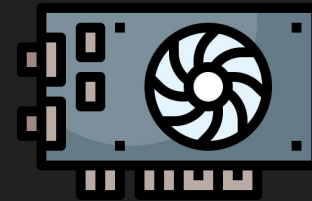
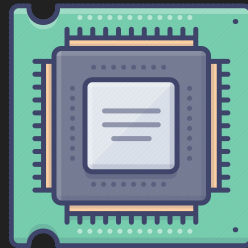

Mining Algorithms



$$\mathcal{F}_d(c, x) \rightarrow \text{SHA256}(\text{SHA256}(c|x)) < \frac{2^{224}}{d}$$

c: challenge
x: nonce
d: difficulty

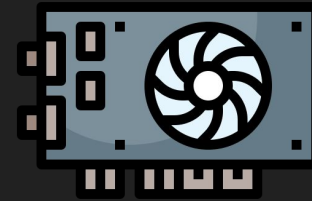
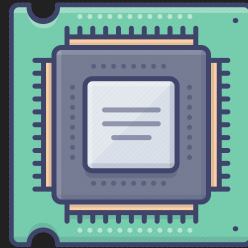

Greedy Heaviest Observed Subtree

Ethereum PoW (GHOST)

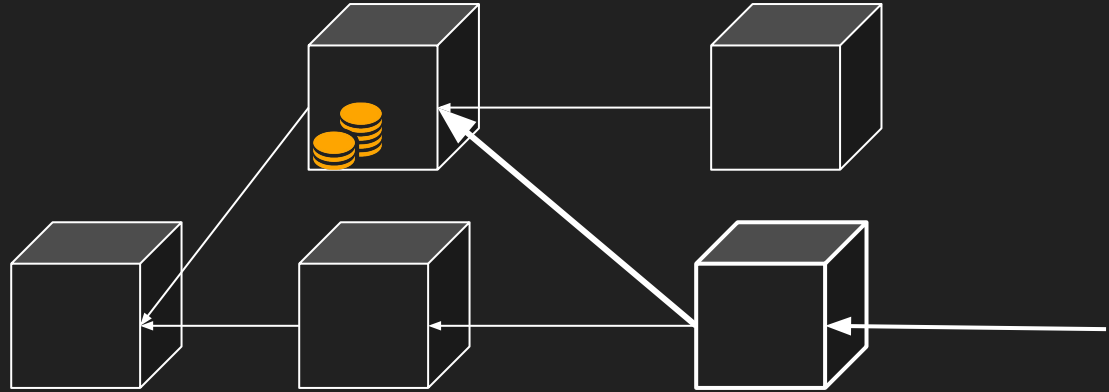

Memory-Hard PoW (GPU mining)

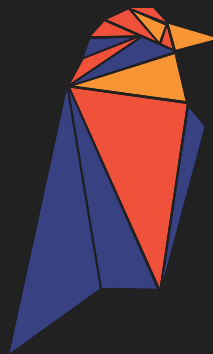
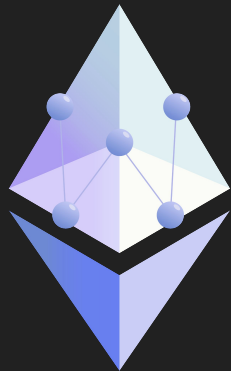
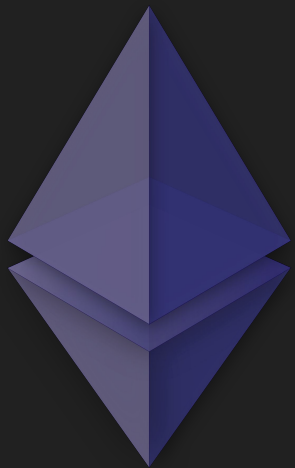



12th September 2022



The Ethereum Merge

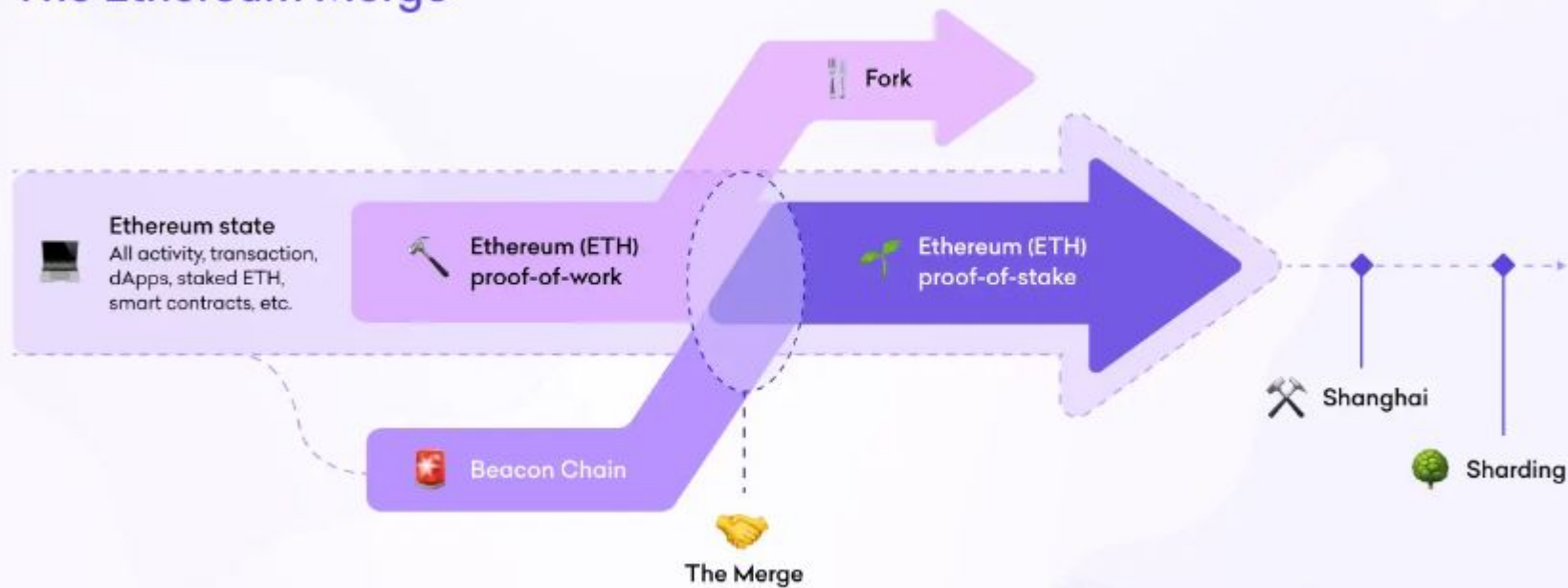

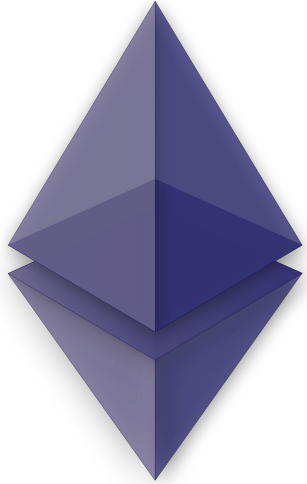

Used ~21 TWh per year.
(~25 % of Bitcoin)

- <https://ccaf.io/cbnsi/cbeci>

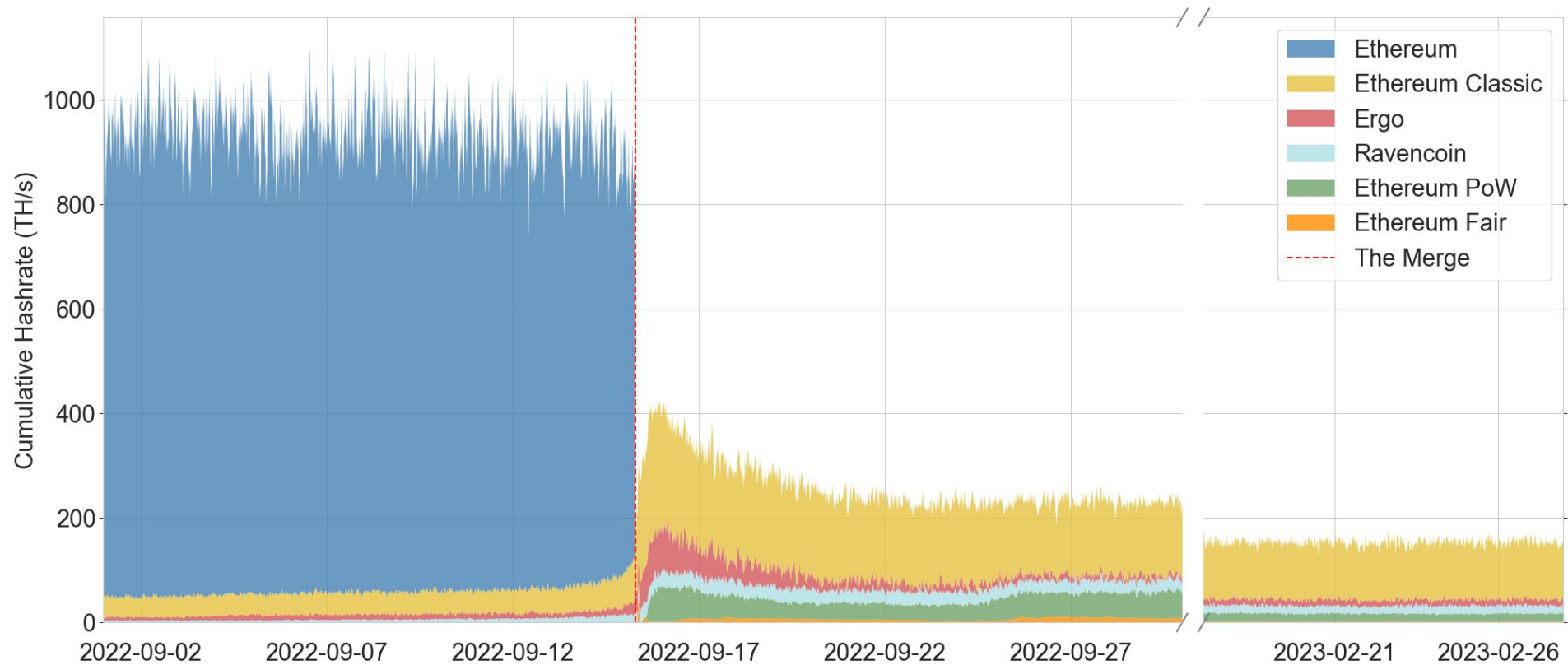

Ethash Equivalent Hashrate

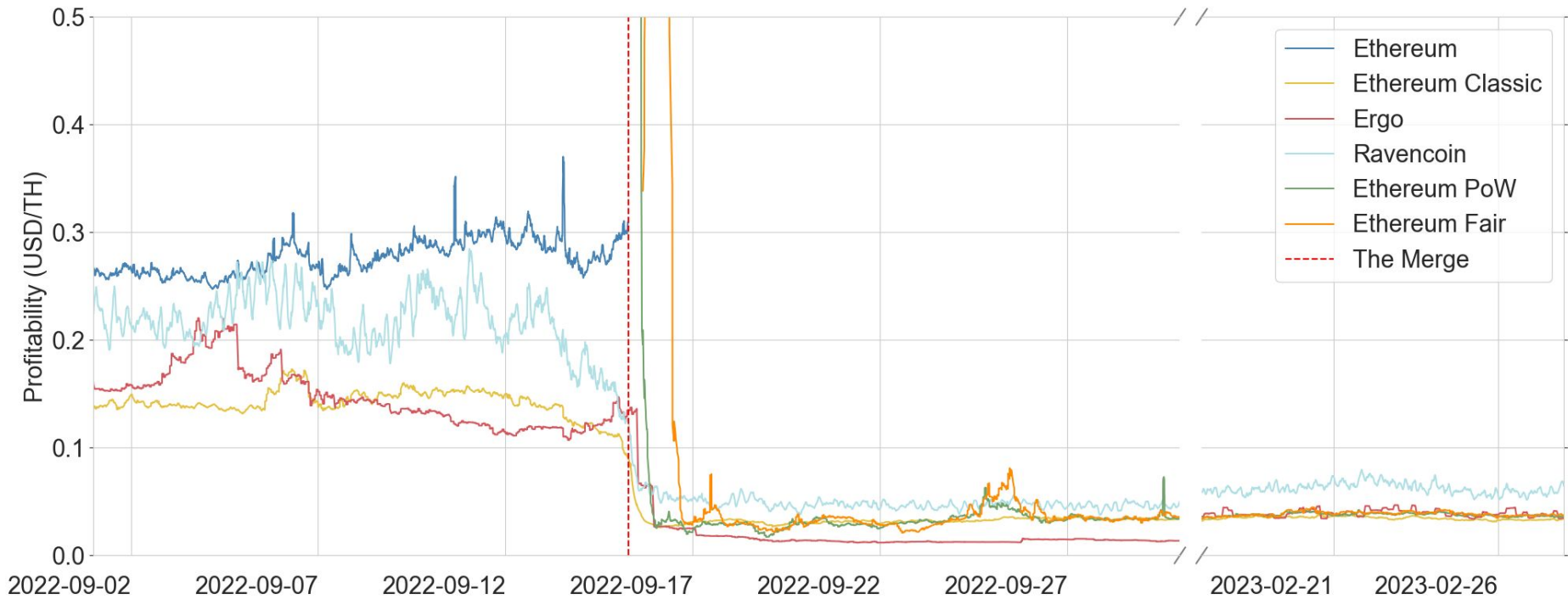

Mining Profitability

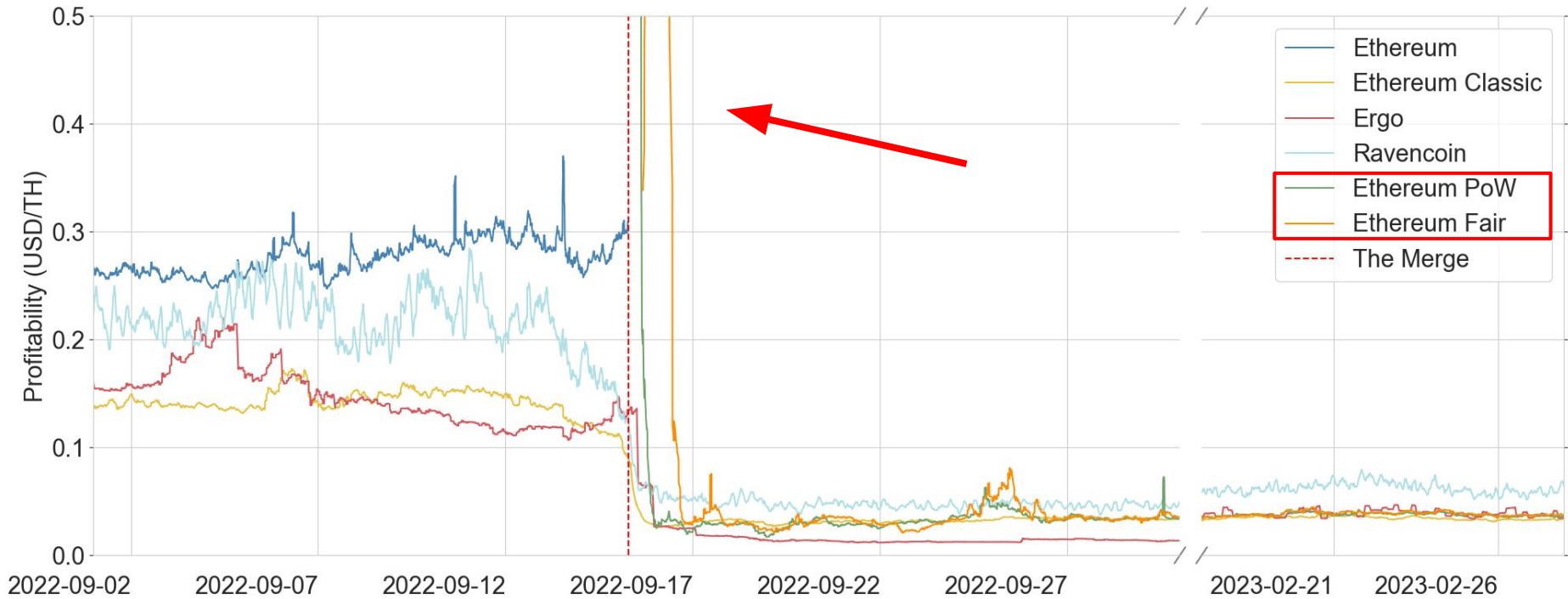

Mining Profitability

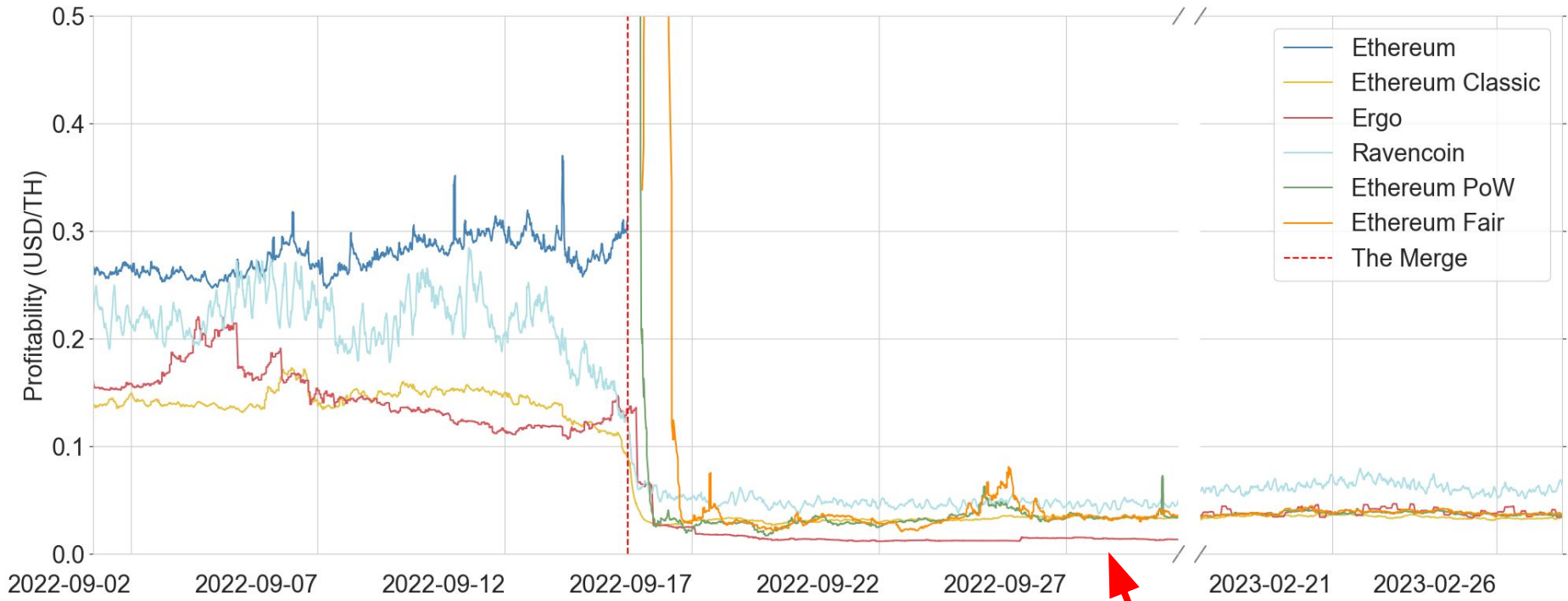

Mining Profitability

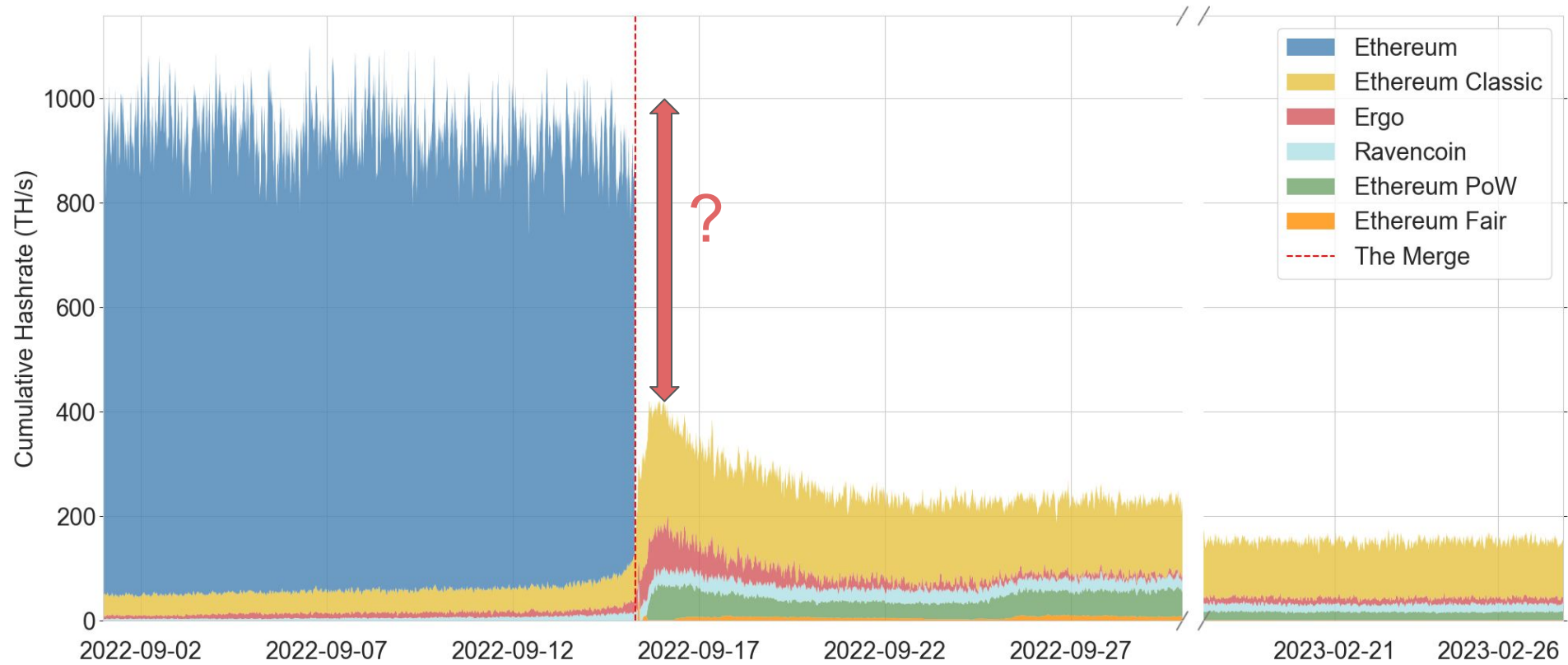

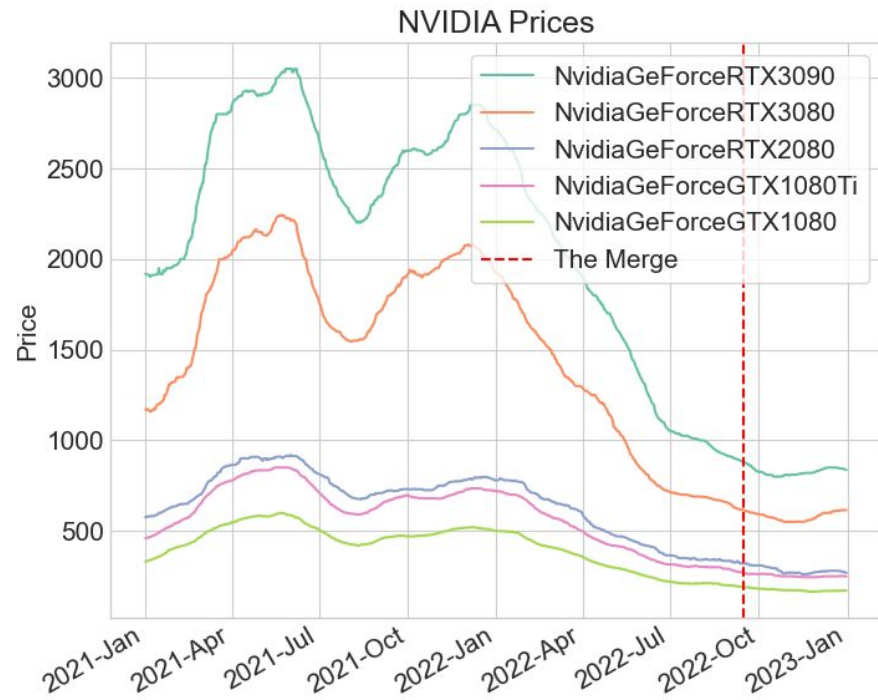
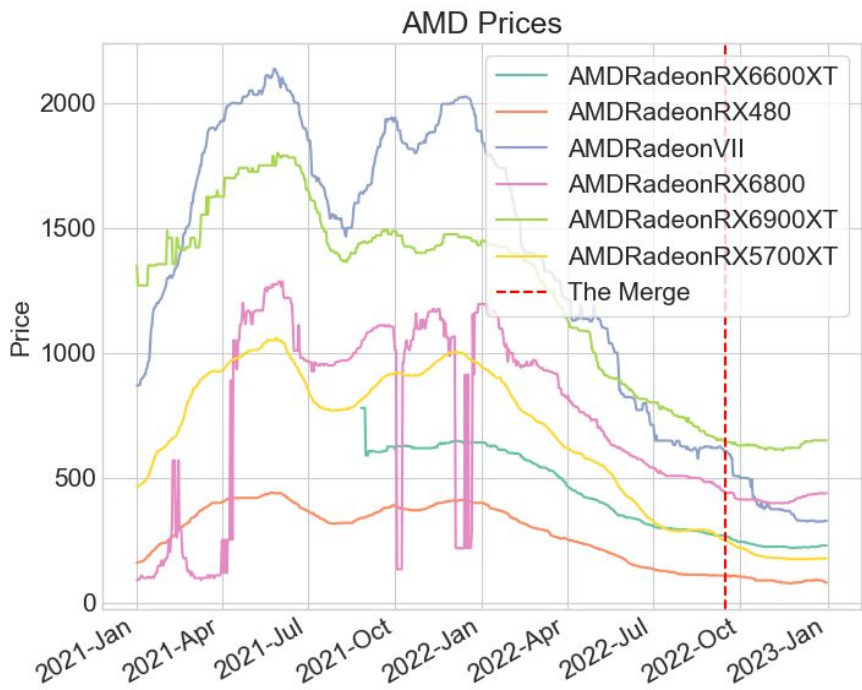

GPU Price Development

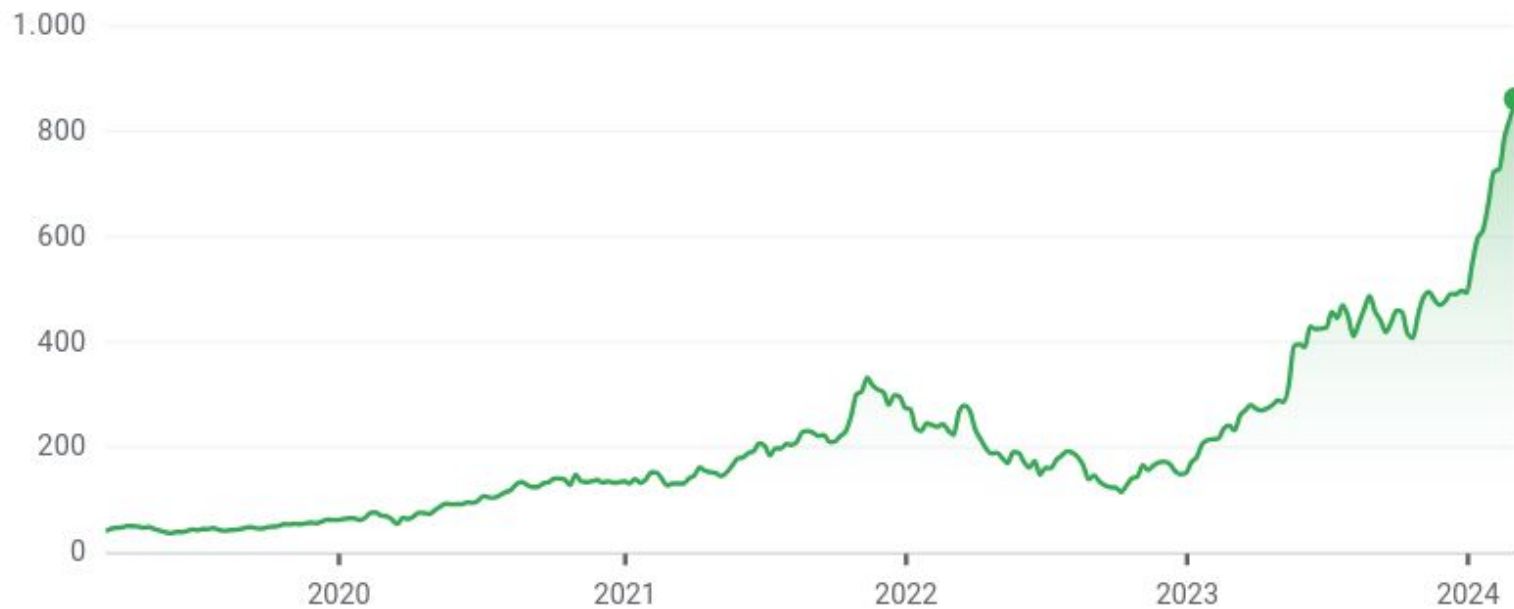

Nvidia Share Price in USD

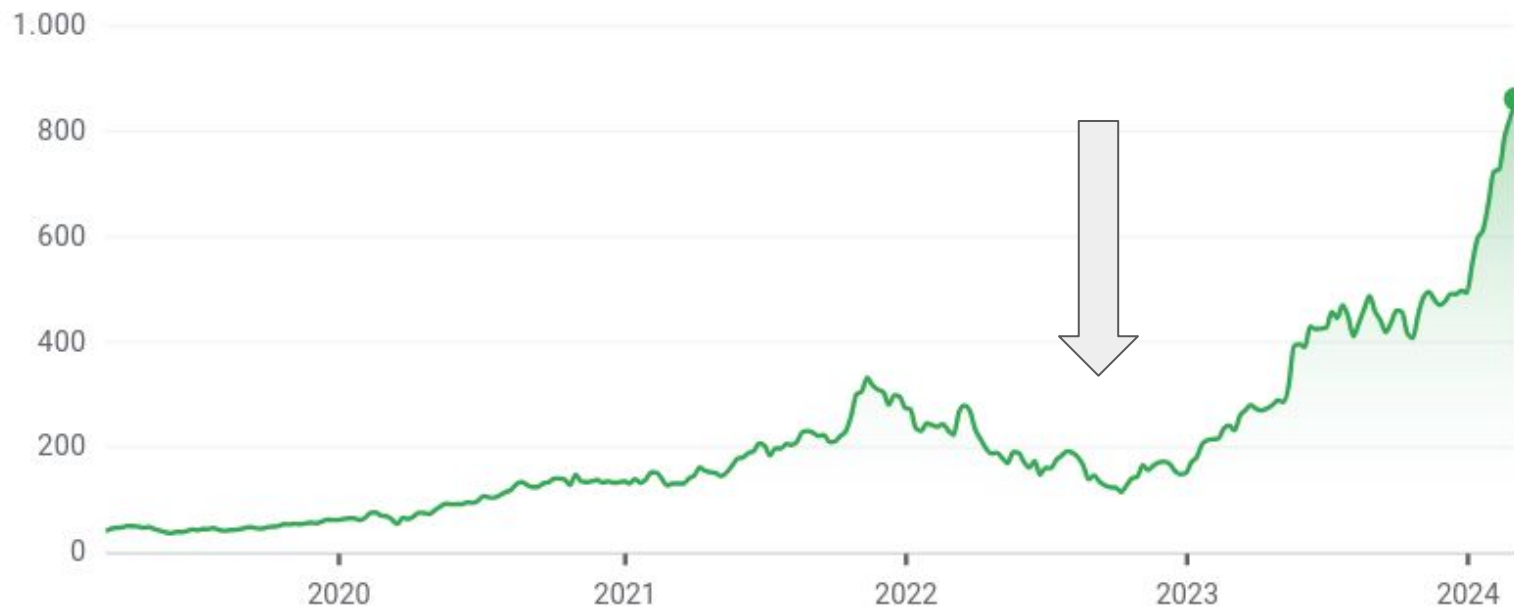

Nvidia Share Price in USD

Blockchain + GPUs ?

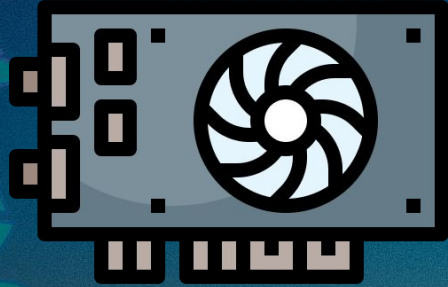

- Layer-1: zkEVM
- Layer-2: Zero-knowledge rollups
- Decentralized GPU Markets

Section 1.2

Proof-of-Stake

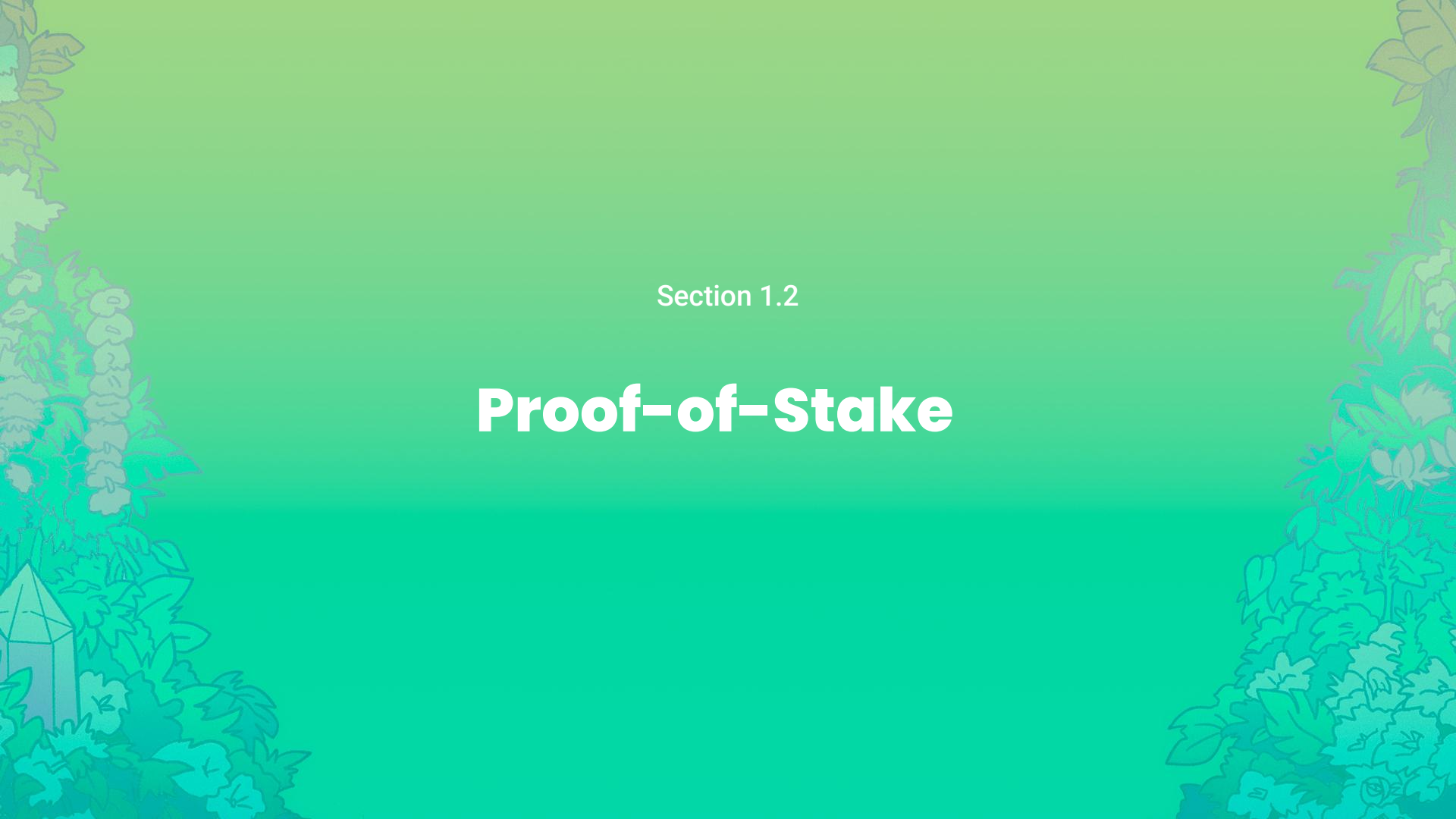

High-level Overview



Application Layer:
Ethereum Virtual Machine (EVM)

Consensus Layer:
Proof-of-Stake (LMD-GHOST & Casper FFG)

Networking Layer:
Peer-to-Peer (libp2p, discv4/5, ...)

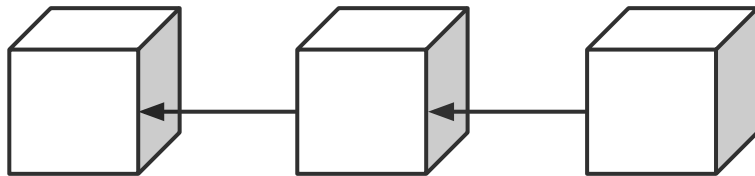

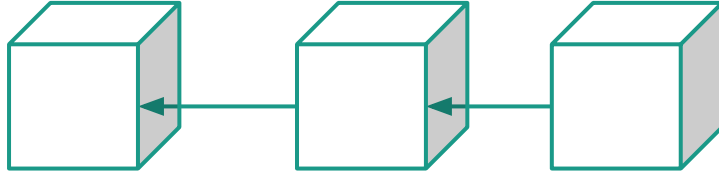

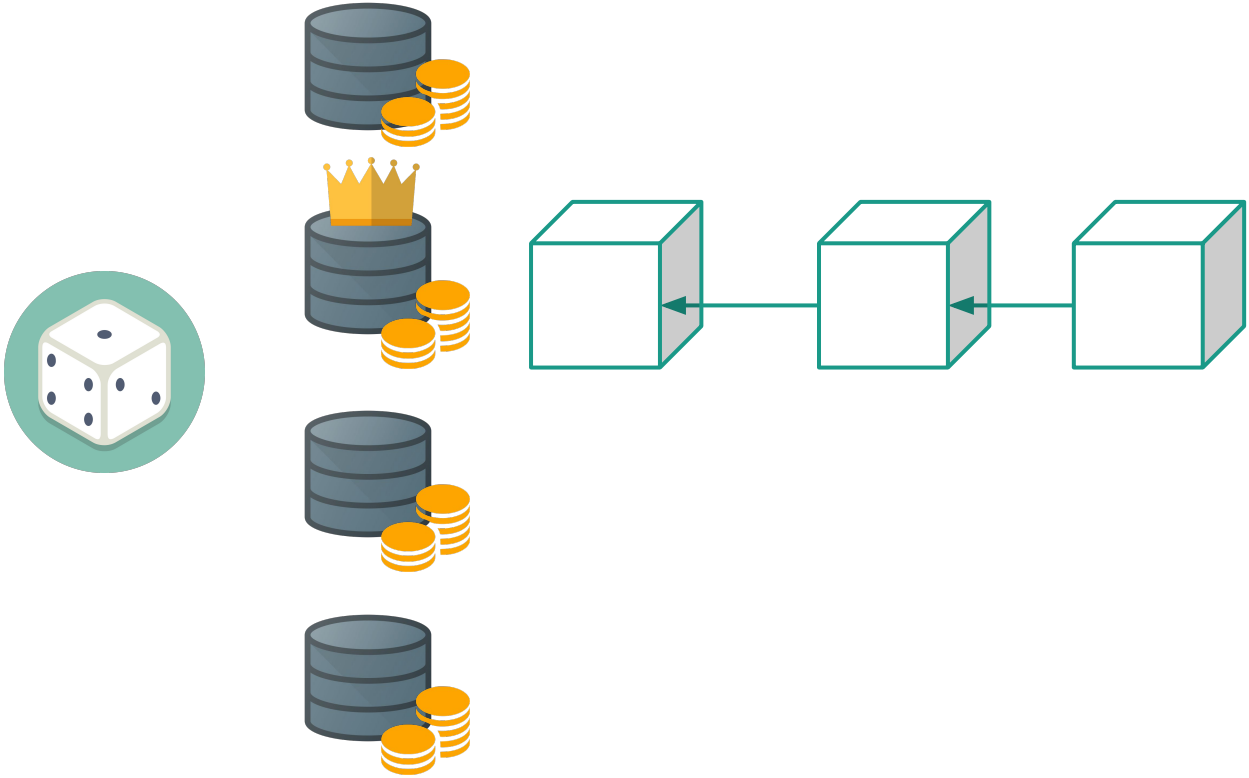

Sybil resistance: Each validator must “stake” 32 ETH

Proof-of-Stake (or Byzantine Fault-Tolerance)



2



1



3



4



Proof-of-Stake (or Byzantine Fault-Tolerance)

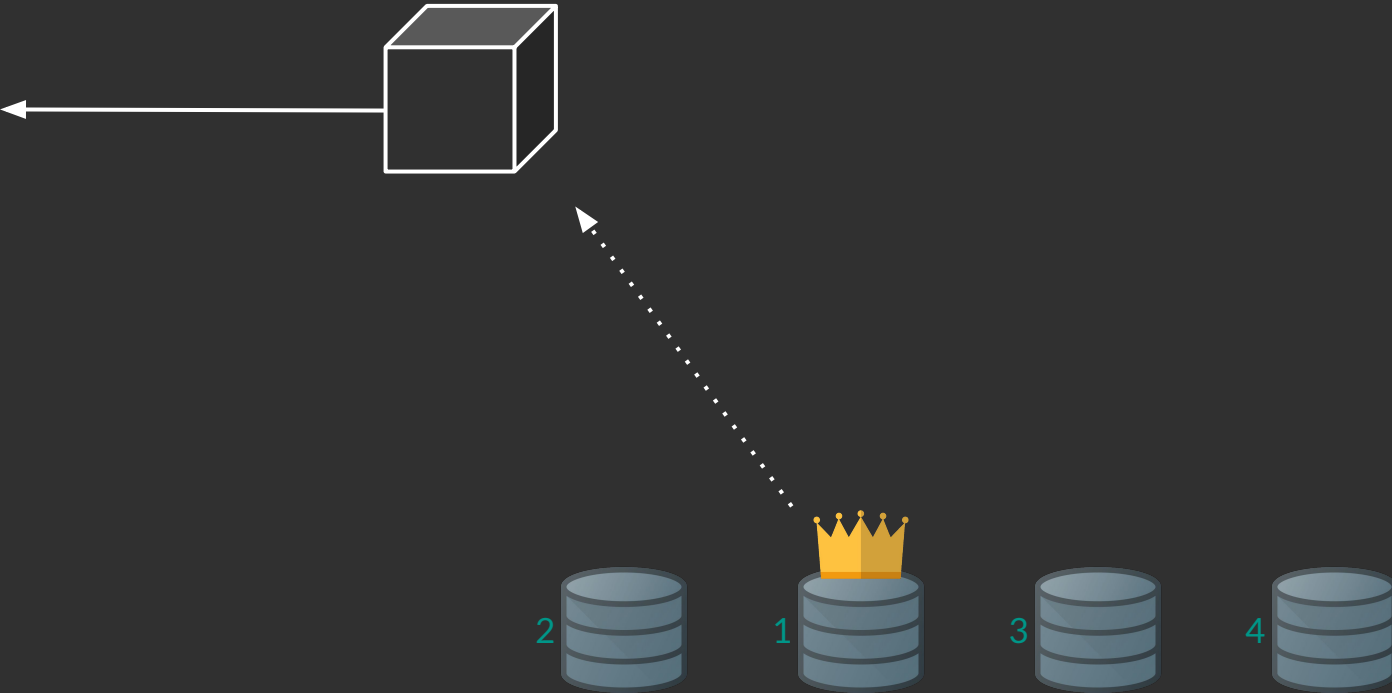

Proof-of-Stake (or Byzantine Fault-Tolerance)

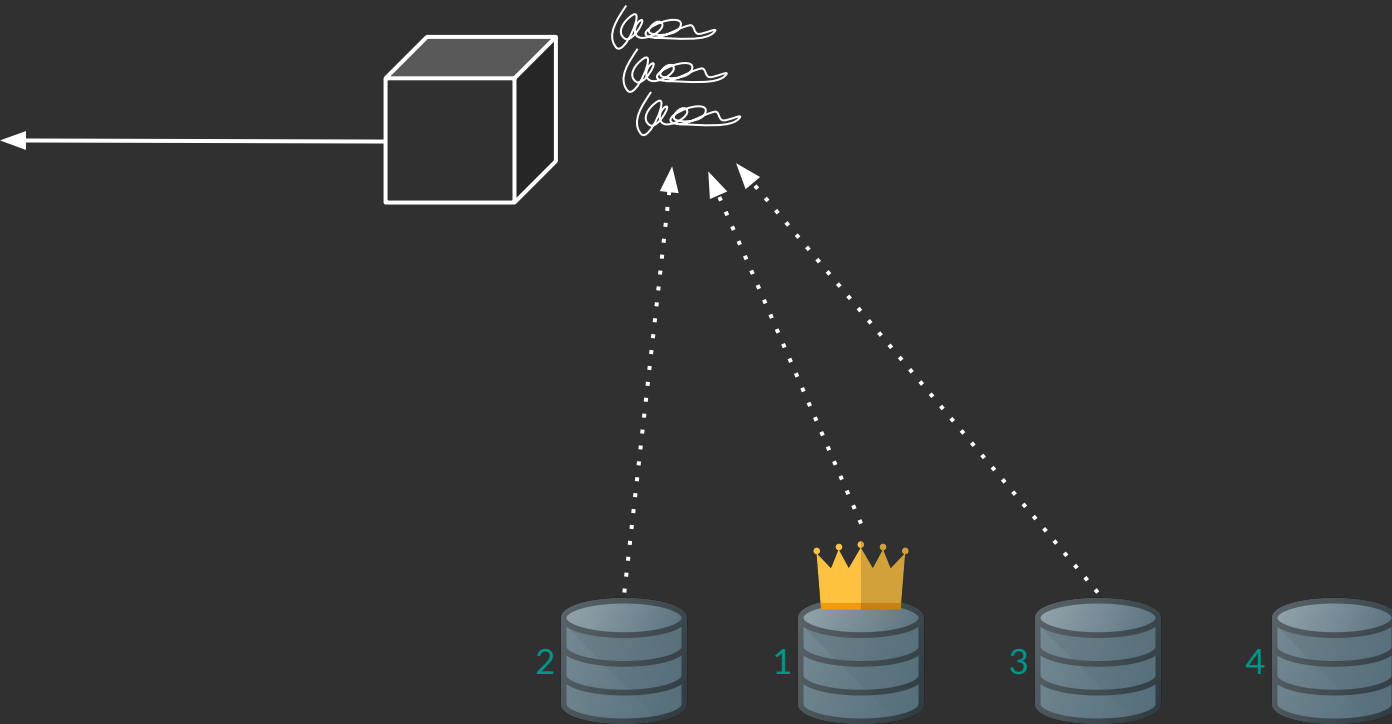

Proof-of-Stake (or Byzantine Fault-Tolerance)



Proof-of-Stake (or Byzantine Fault-Tolerance)



4



2



1



3



Proof-of-Stake (or Byzantine Fault-Tolerance)

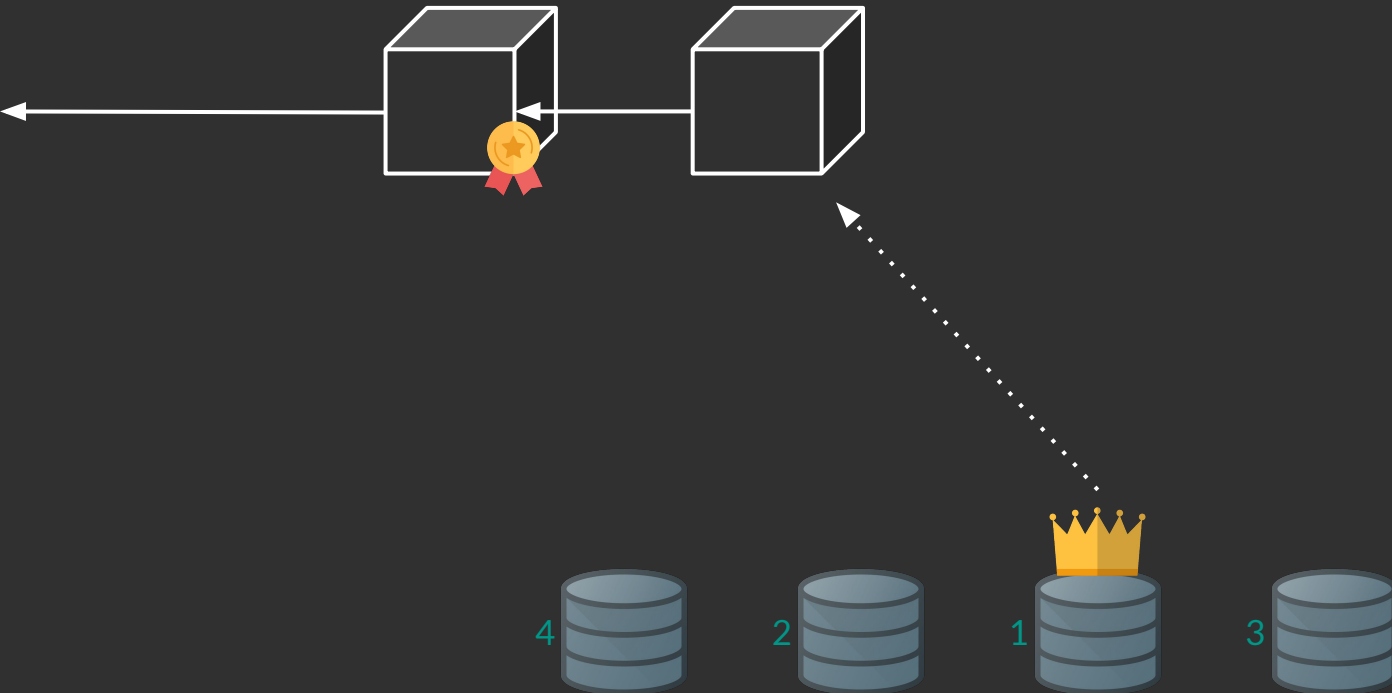

Proof-of-Stake (or Byzantine Fault-Tolerance)

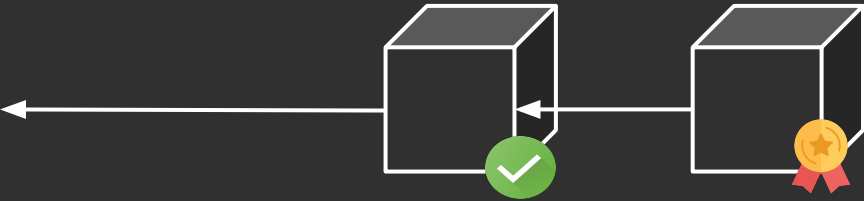

Proof-of-Stake (or Byzantine Fault-Tolerance)

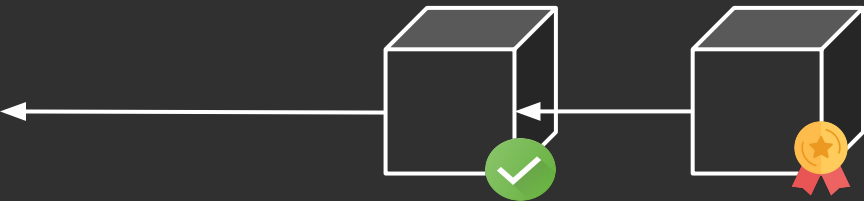

Proof-of-Stake (or Byzantine Fault-Tolerance)

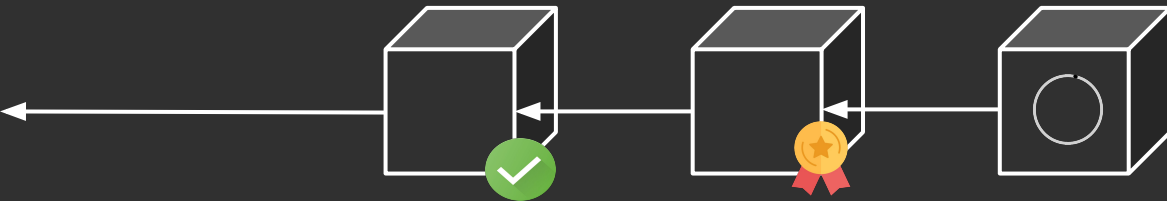

Proof-of-Stake (or Byzantine Fault-Tolerance)

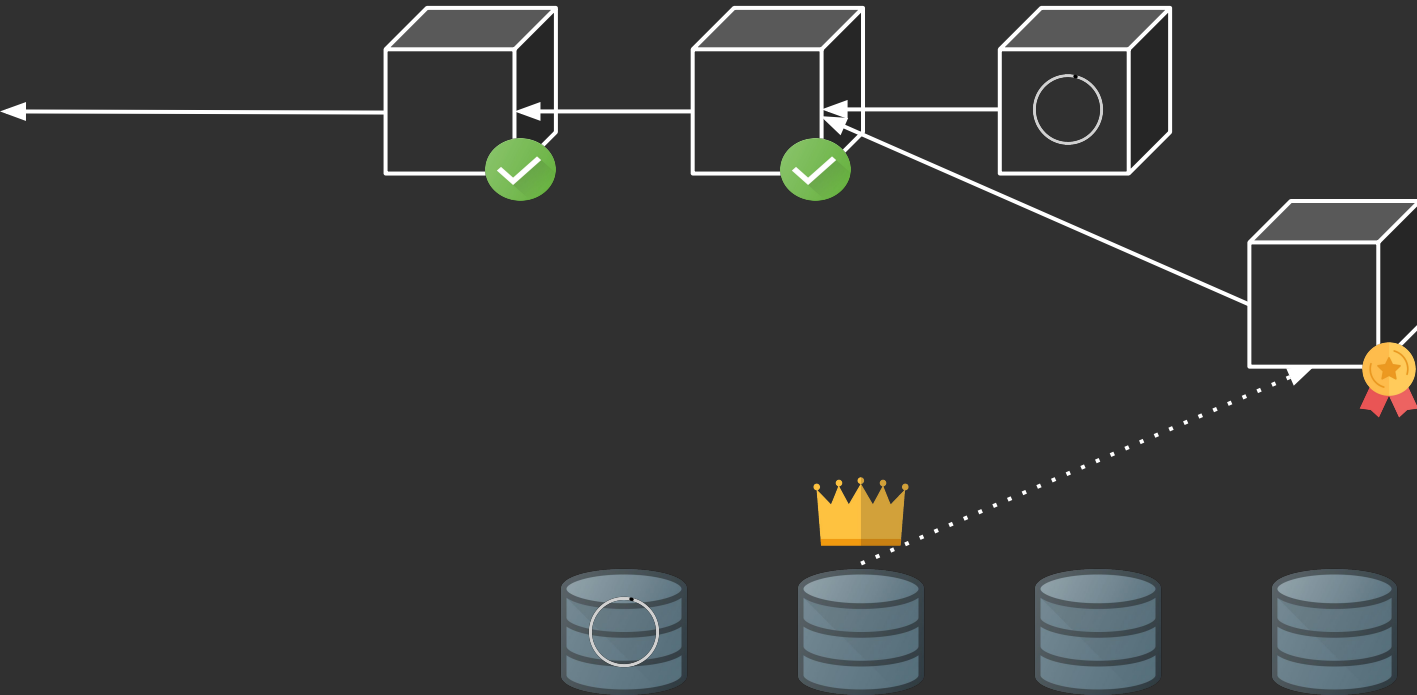

Proof-of-Stake (or Byzantine Fault-Tolerance)

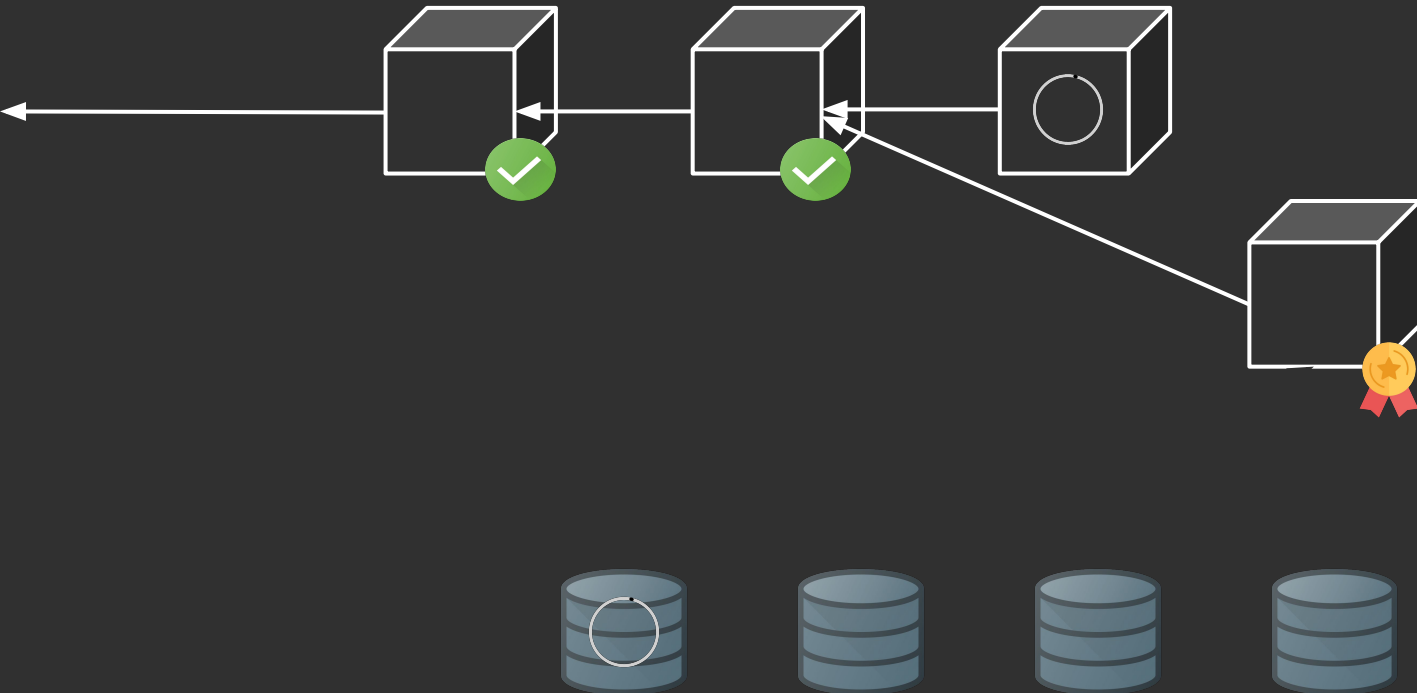

376492 epoch complete

Epoch
376,492 / 376,489

Current Slot
12,047,773

Active Validators
1,086,057

Joining / Leaving
226K / 1K ETH

Staked ETH
35,406,189 ETH

Average Balance
32.66 ETH

Network History

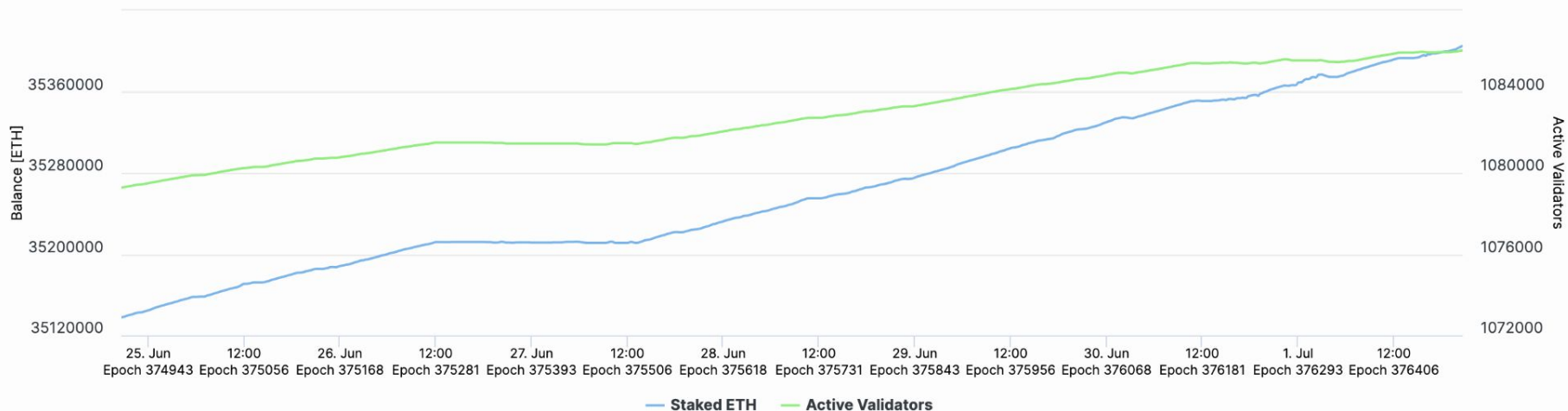

<https://beaconcha.in/>

376492 epoch complete

Epoch
376,492 / 376,489

Current Slot
12,047,773

Active Validators
1,086,057

Joining / Leaving
226K / 1K ETH

Staked ETH
35,406,189 ETH

Average Balance
32.66 ETH

Network History

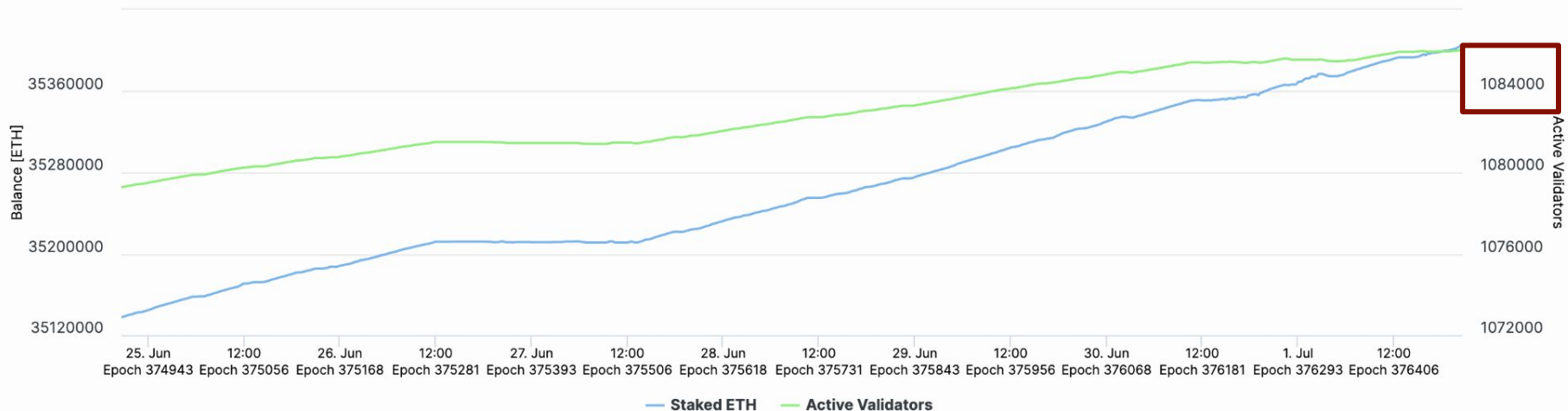

<https://beaconcha.in/>

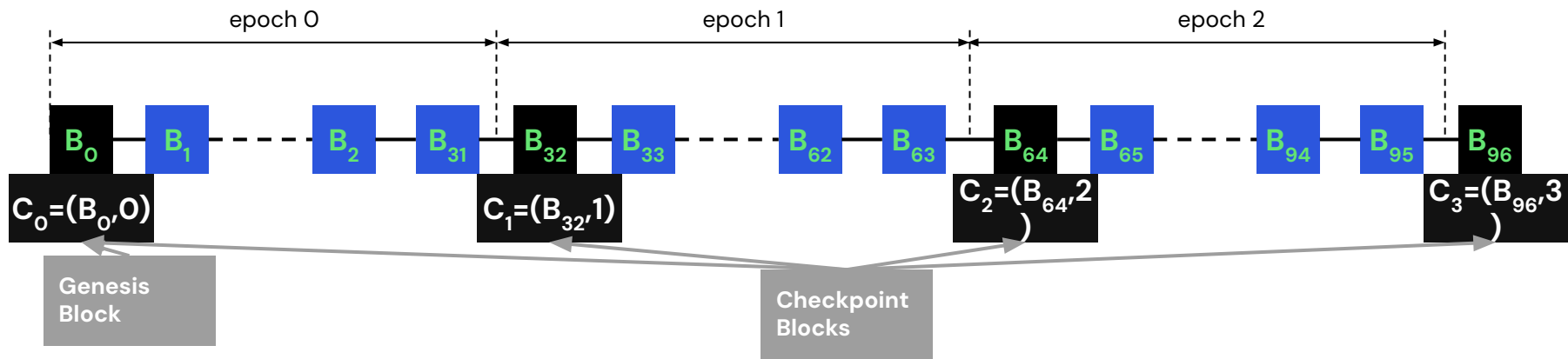

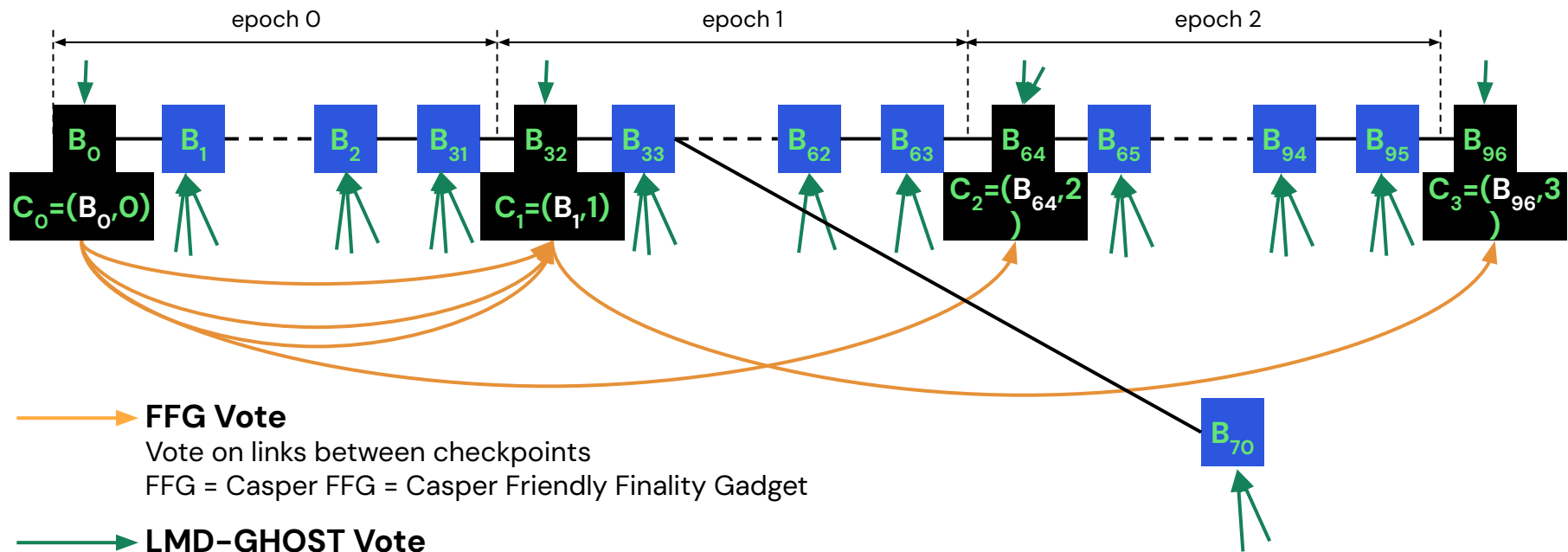

FFG Vote

Vote on links between checkpoints
 FFG = Casper Friendly Finality Gadget

LMD-GHOST Vote

Vote on blocks
 LMD-GHOST = Latest Message Driven Greediest Heaviest Observed SubTree

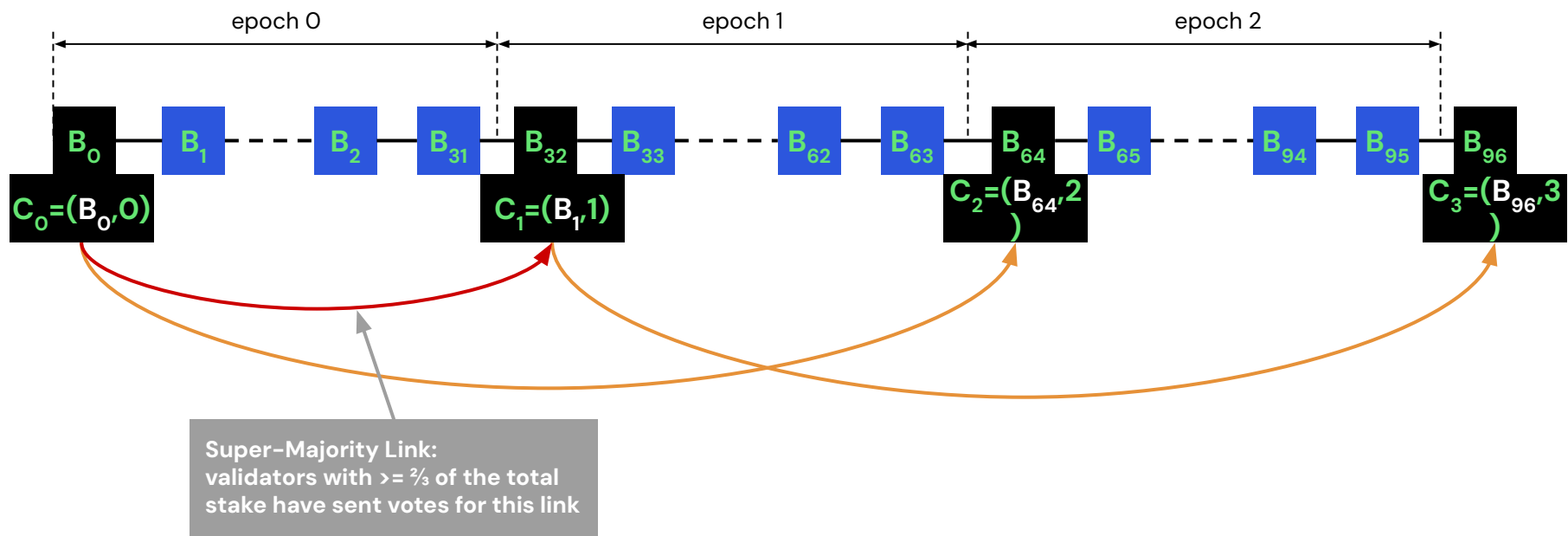

LMD-GHOST and Casper FFG

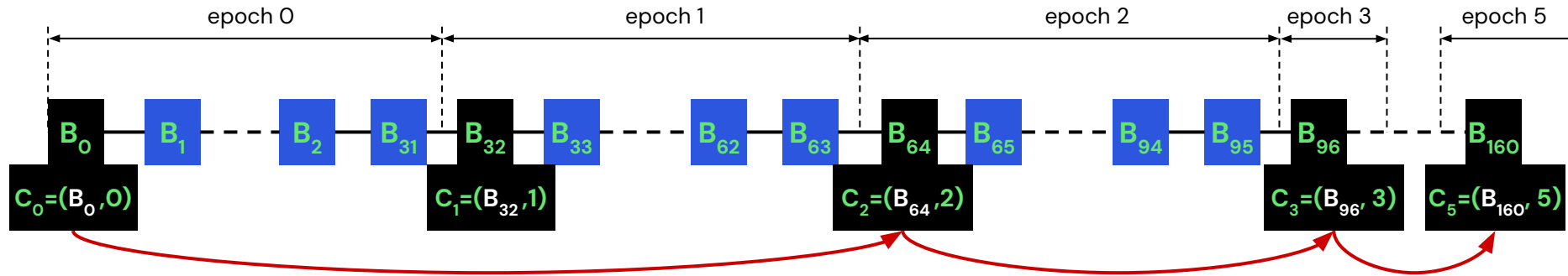

Justified 

Finalized 

Justified 

Finalized 

Justified 

Justified 

How do validators cast FFG votes?

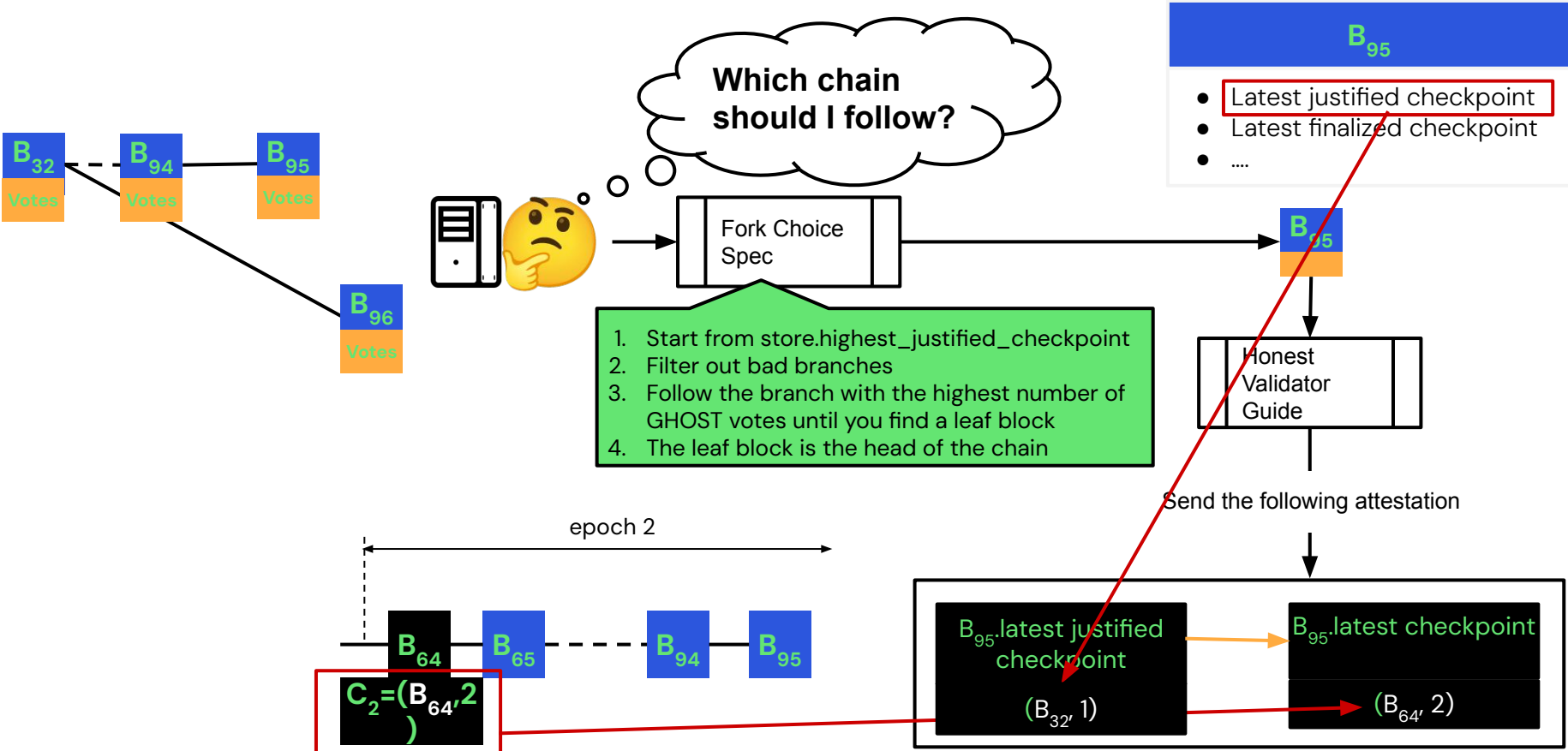

Slashable Offences

If a validator commits a slashable offence

- its stake will be slashed by X
- it will be forced to exit the validator set

Double
Vote

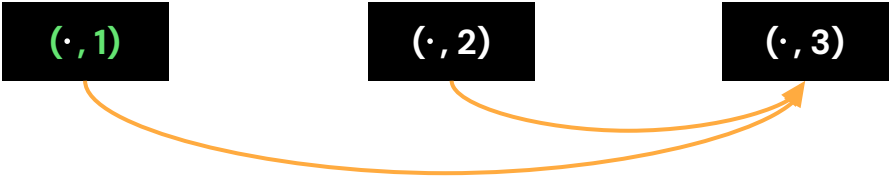

Surround
Vote



↻ Most recent epochs

[View more](#)

Epoch	Time	Final	Eligible (ETH)	Voted
376,491	4 mins ago	No	35,406,189	Calculating...
376,490	10 mins ago	No	35,405,933	<u>34,214,022</u> (96.63%)
376,489	17 mins ago	No	35,405,677	<u>34,195,777</u> (96.58%)
376,488	23 mins ago	Yes	35,405,421	<u>35,288,024</u> (99.67%)
376,487	30 mins ago	Yes	35,404,973	<u>35,310,923</u> (99.73%)
376,486	36 mins ago	Yes	35,404,461	<u>35,323,662</u> (99.77%)
376,485	42 mins ago	Yes	35,404,045	<u>35,322,715</u> (99.77%)
376,484	49 mins ago	Yes	35,403,564	<u>35,309,786</u> (99.74%)
376,483	55 mins ago	Yes	35,403,052	<u>35,322,628</u> (99.77%)
376,482	1 hr 2 mins ago	Yes	35,402,572	<u>35,317,373</u> (99.76%)
376,481	1 hr 8 mins ago	Yes	35,402,124	<u>35,320,467</u> (99.77%)
376,480	1 hr 14 mins ago	Yes	35,401,676	<u>35,330,914</u> (99.8%)
376,479	1 hr 21 mins ago	Yes	35,401,482	<u>35,323,044</u> (99.78%)
376,478	1 hr 27 mins ago	Yes	35,401,194	<u>35,229,601</u> (99.52%)
376,477	1 hr 34 mins ago	Yes	35,401,093	<u>35,321,570</u> (99.78%)

Dashboard

beaconcha.in



Protocol Overview

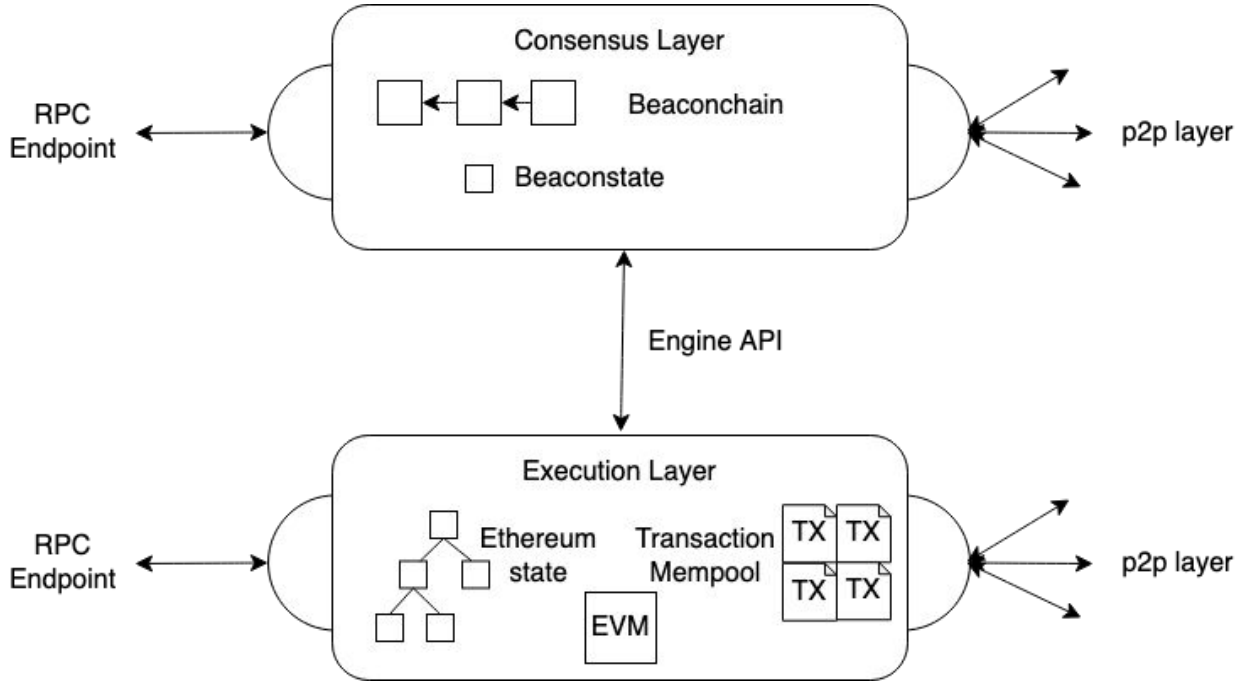

Section 2

Nodes and Validators



High-level Overview

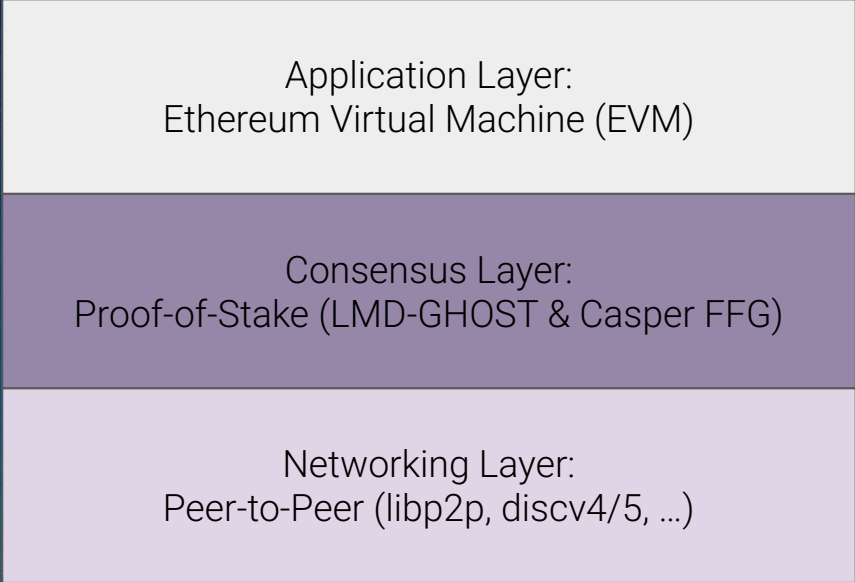

Application Layer:
Ethereum Virtual Machine (EVM)

Consensus Layer:
Proof-of-Stake (LMD-GHOST & Casper FFG)

Networking Layer:
Peer-to-Peer (libp2p, discv4/5, ...)

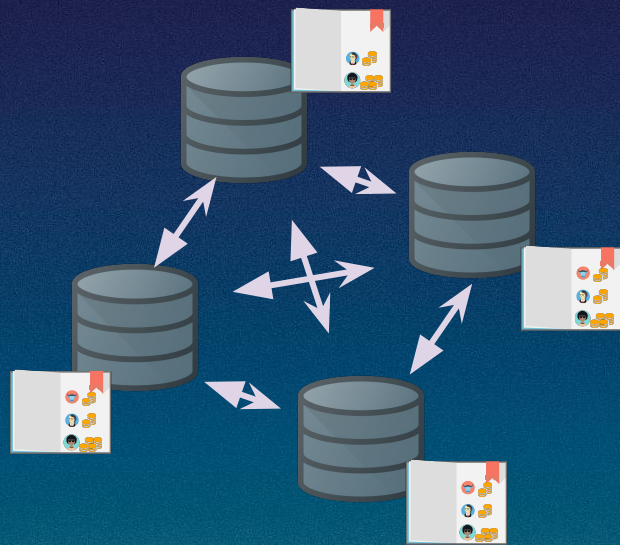

No Owner or Operator

No single entity can:

- Process transactions incorrectly.
- Remove or alter previous transactions.
- Turn the blockchain off.



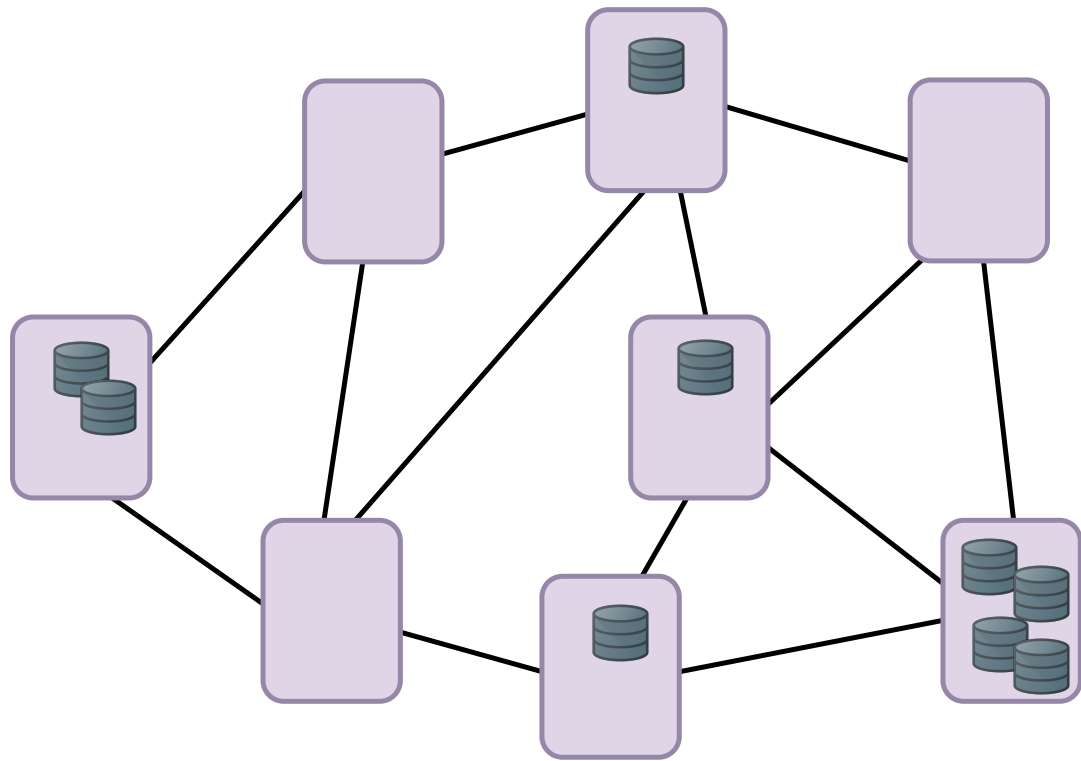

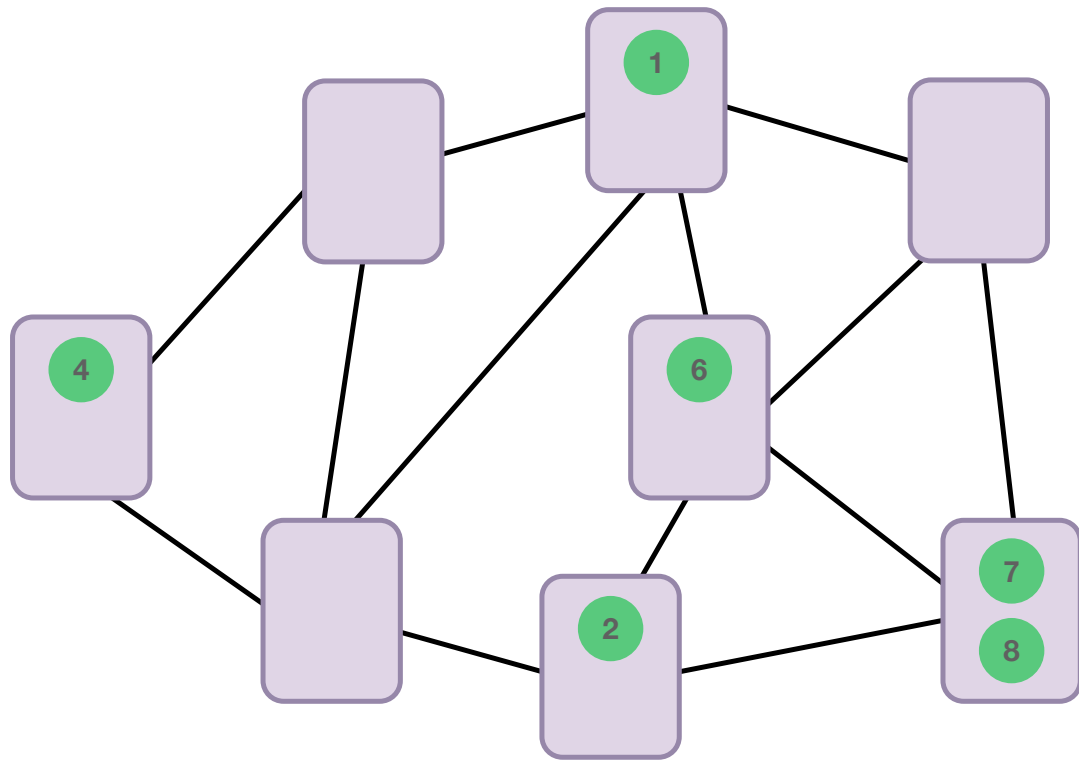



- **Entities in charge of consensus**
- Have unique Validator ID



- Entities **in charge of consensus**
- Have unique Validator ID
- Periodically **propose a new block** to add to the blockchain



- Entities **in charge of consensus**
- Have unique Validator ID
- Periodically **propose a new block** to add to the blockchain
- Once per epoch **attest on their view** of the blockchain (called an **Attestation**)

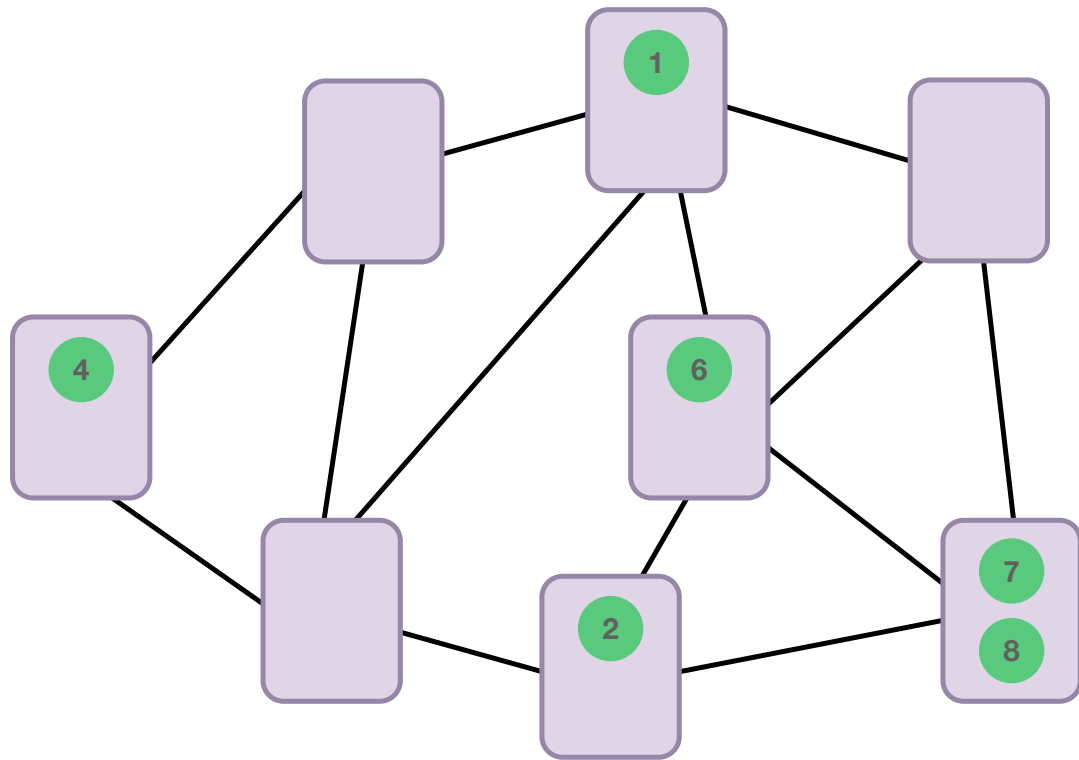

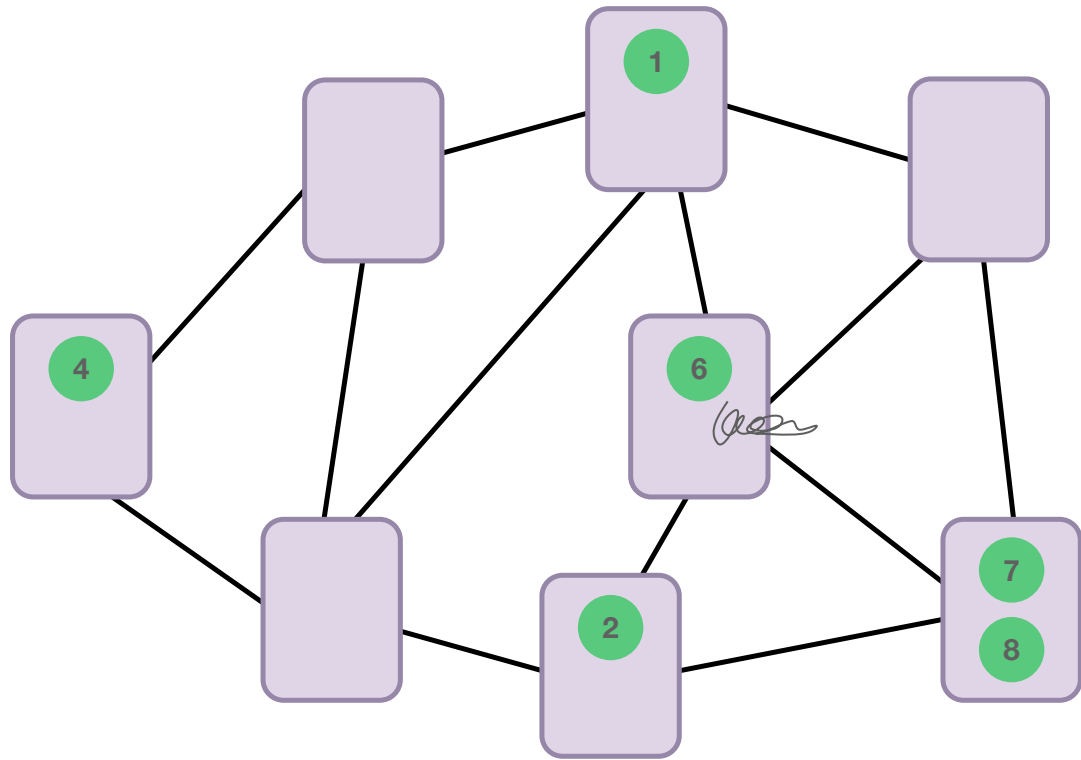

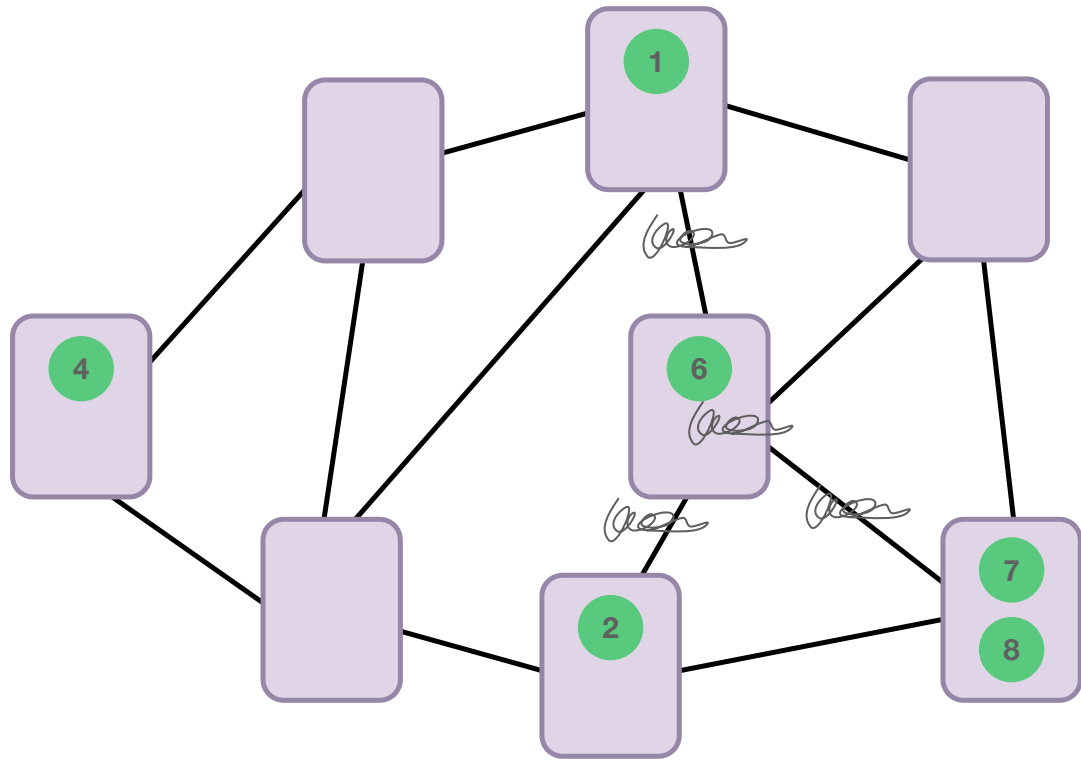

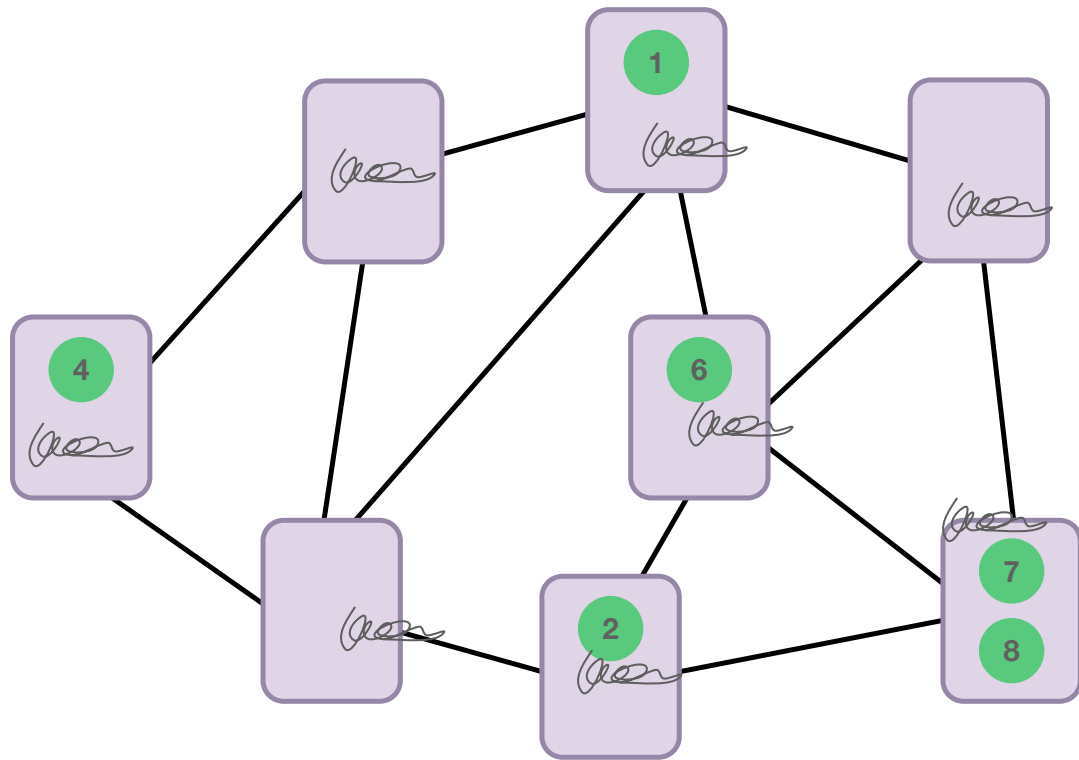

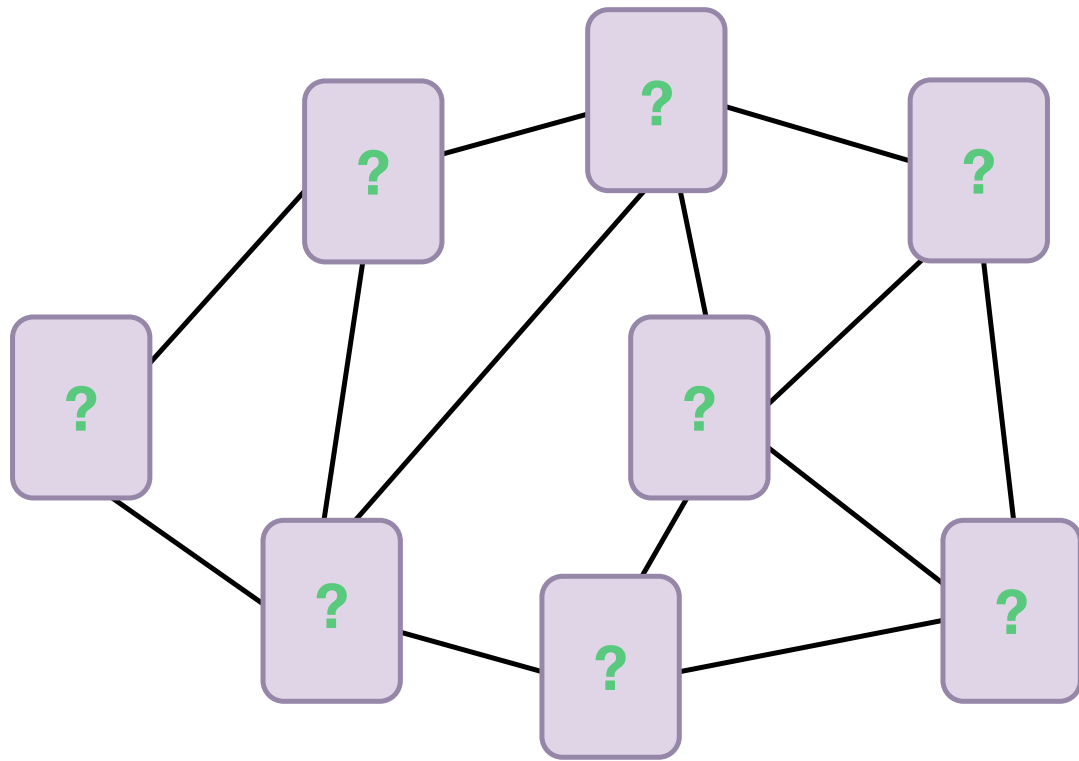

Consensus Clients

! Client diversity has improved!

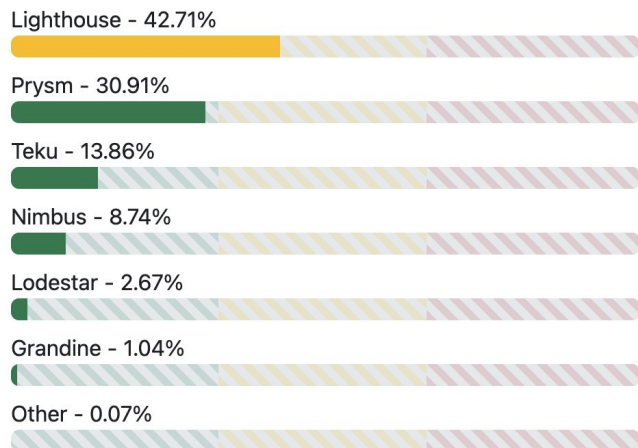

Data provided by [Miga Labs](#) — updated daily.
Data may not be 100% accurate. ([Read more](#))

Data source (read more):

Miga Labs Rated.Network

Dashboard: Client Diversity

<https://clientdiversity.org/>

Unique in Ethereum: Many independent client implementations for added security.

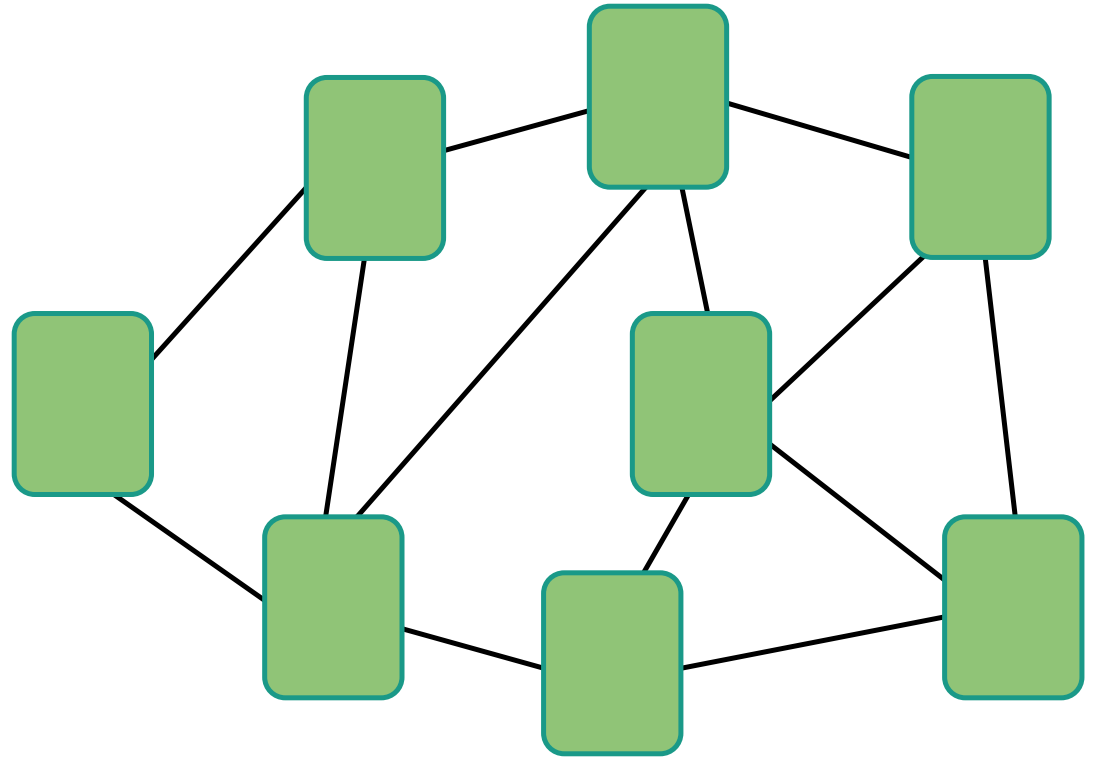
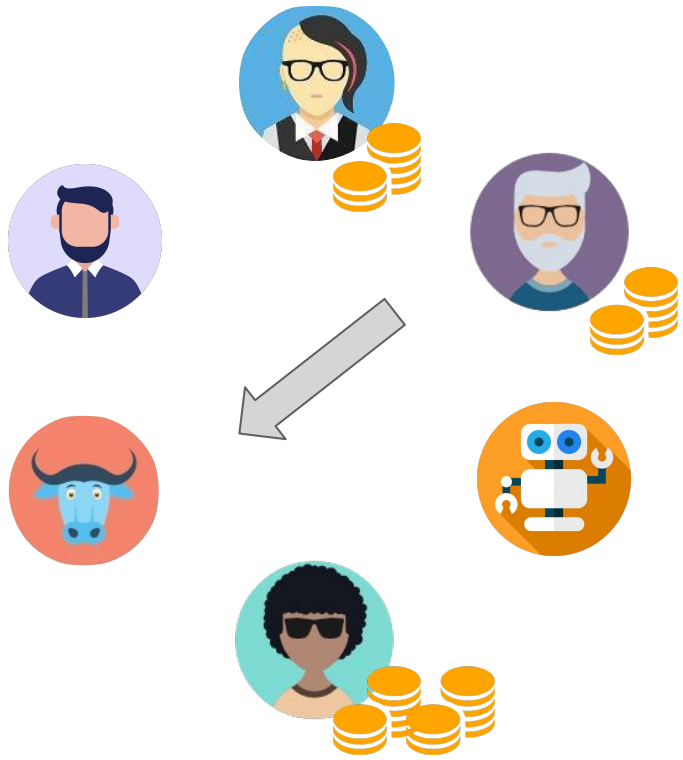

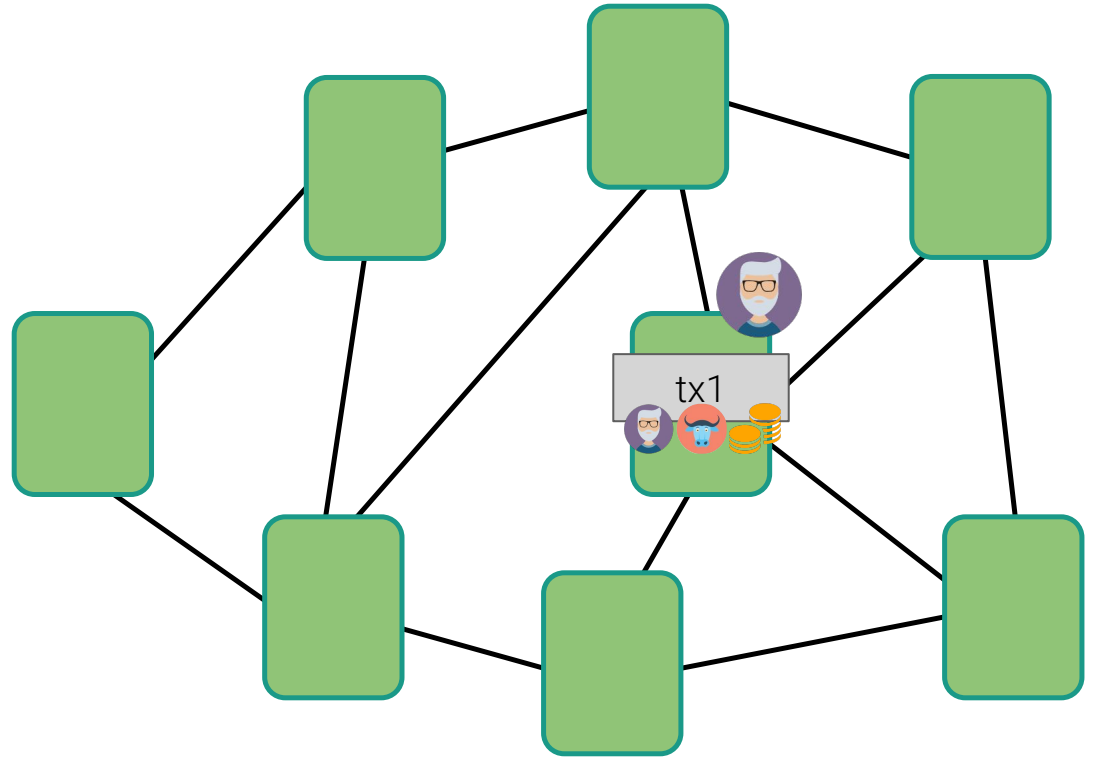
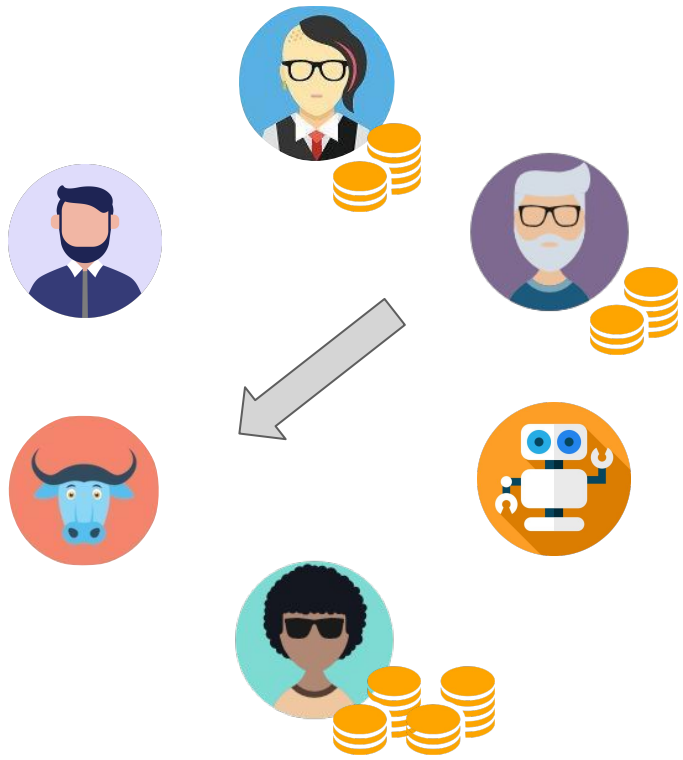

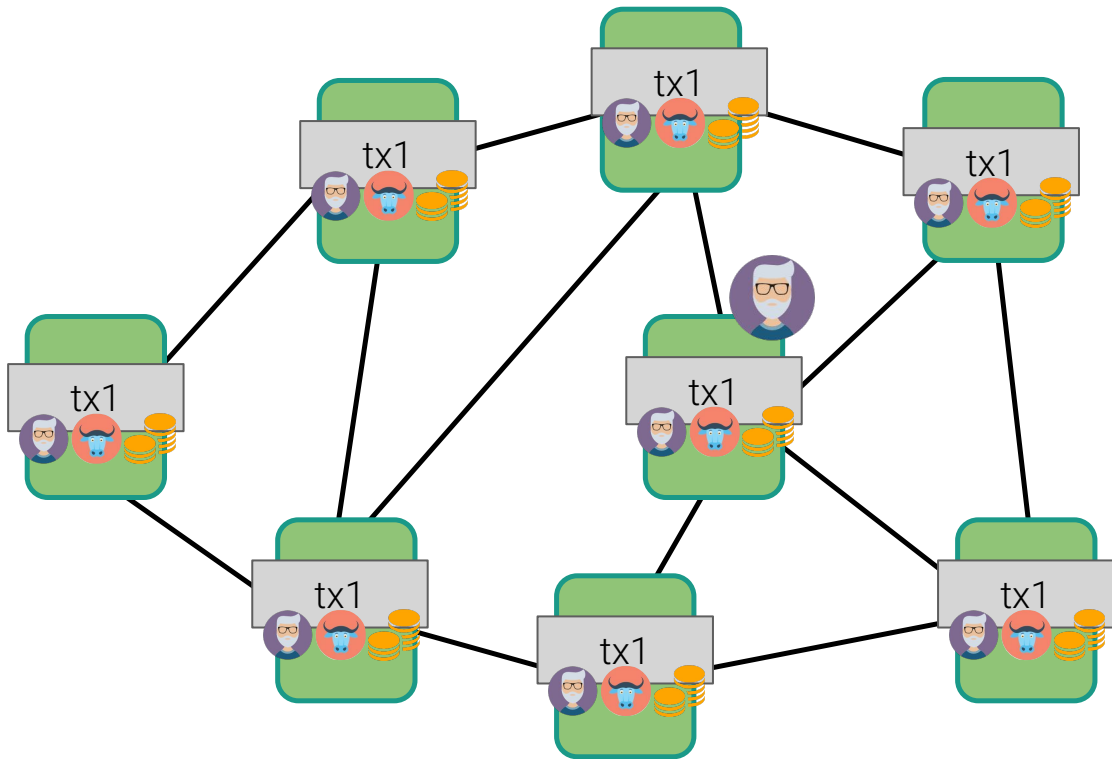
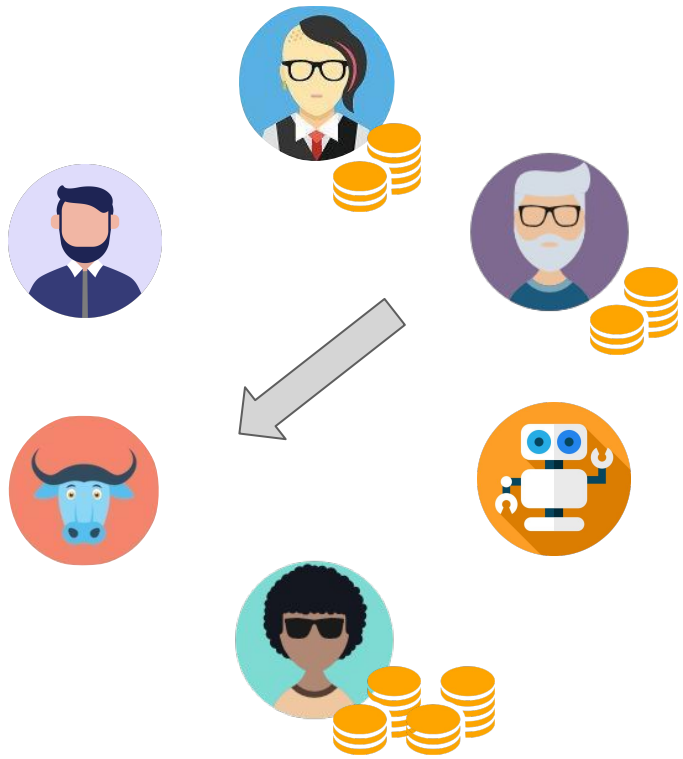

Execution Clients

! Client diversity has improved!

Geth - 41%



Nethermind - 38%



Besu - 16%



Erigon - 3%



Reth - 2%



Other - 0%



Data provided by supermajority.info — updated manually.

Data may not be 100% accurate. ([Read more](#))

Based on 73.9% self-reported network coverage with the remaining assumed to be mostly Geth.

Data source ([read more](#)):

Supermajority.info Ethernodes

Dashboard: Client Diversity

<https://clientdiversity.org/>

Unique in Ethereum: Many independent client implementations for added security.

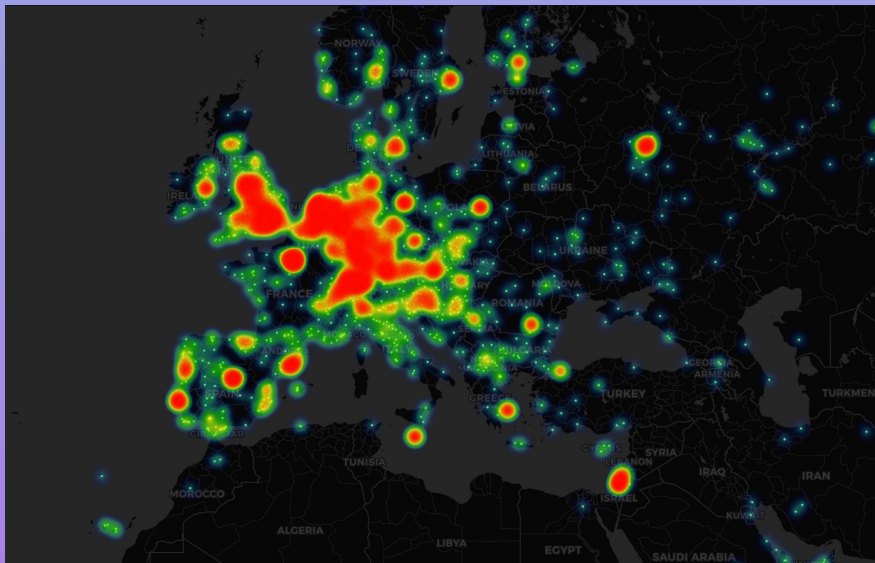

Dashboard: Geo-Distribution

<https://chainbound.grafana.net/public-dashboards/d001850804e1454fa24852c9dd82db97>

Protocol Overview

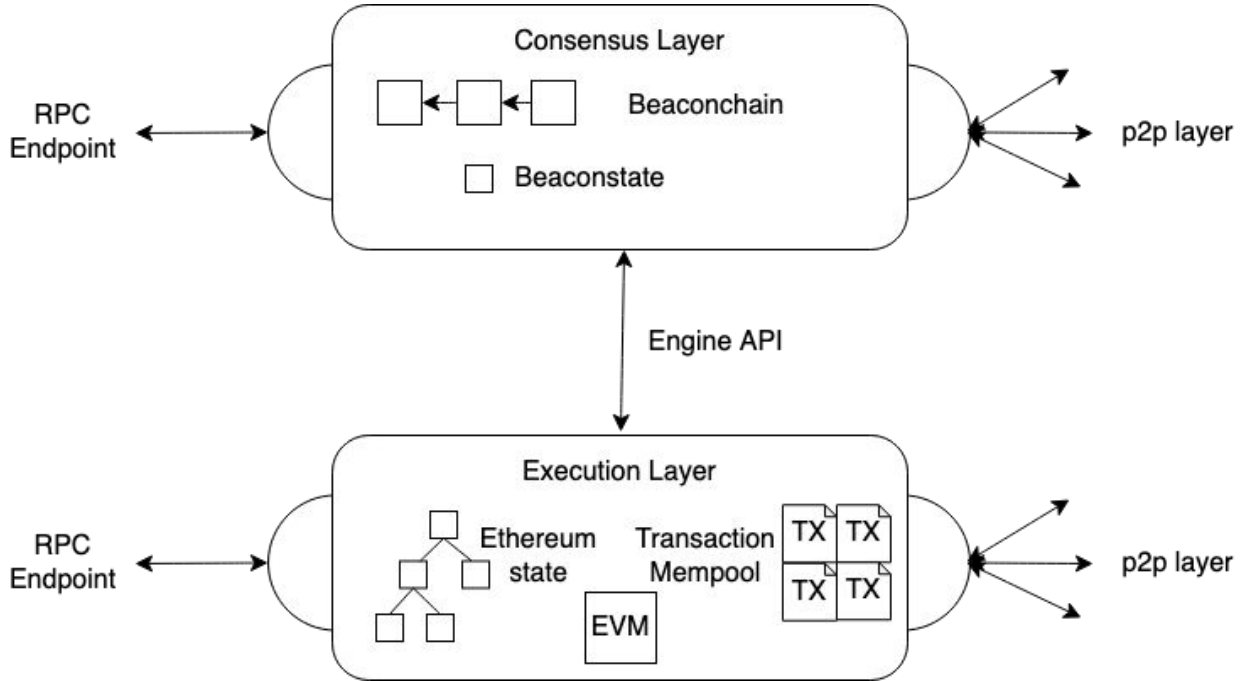

Protocol Overview

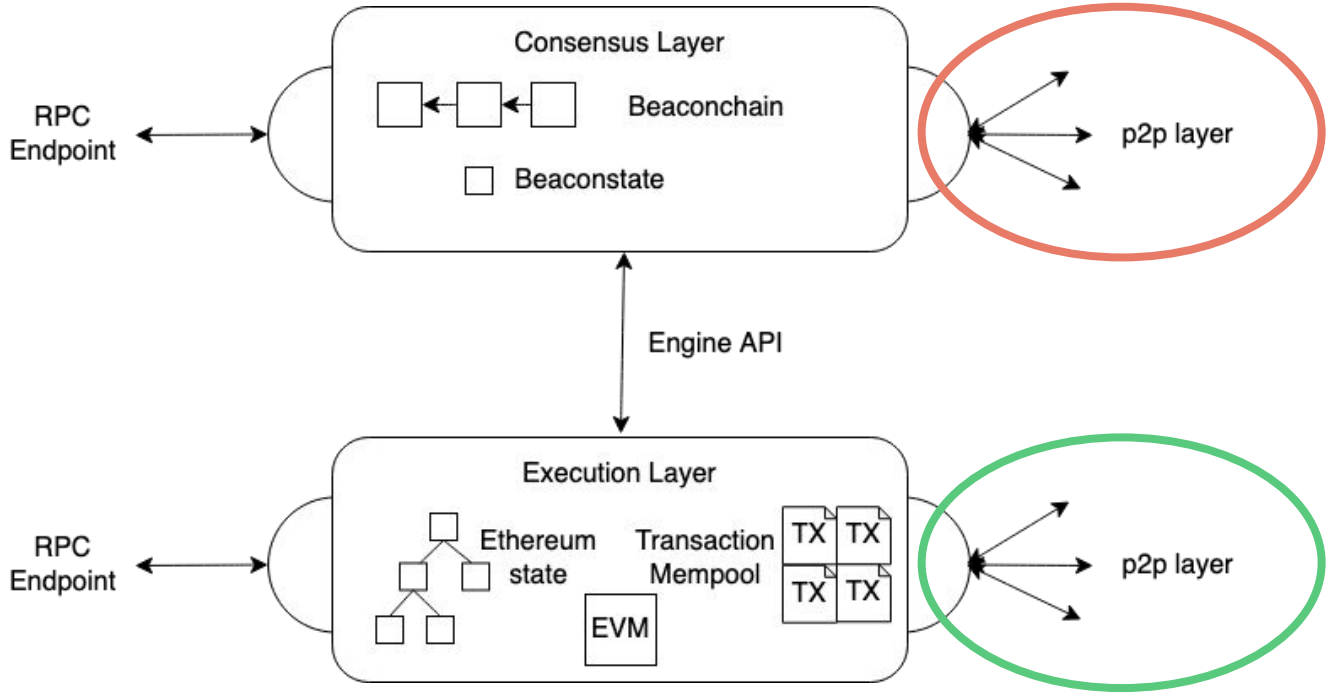

Section 3

Smart Contracts



High-level Overview



Application Layer:
Ethereum Virtual Machine (EVM)

Consensus Layer:
Proof-of-Stake (LMD-GHOST & Casper FFG)

Networking Layer:
Peer-to-Peer (libp2p, discv4/5, ...)



Transaction



EVM



State

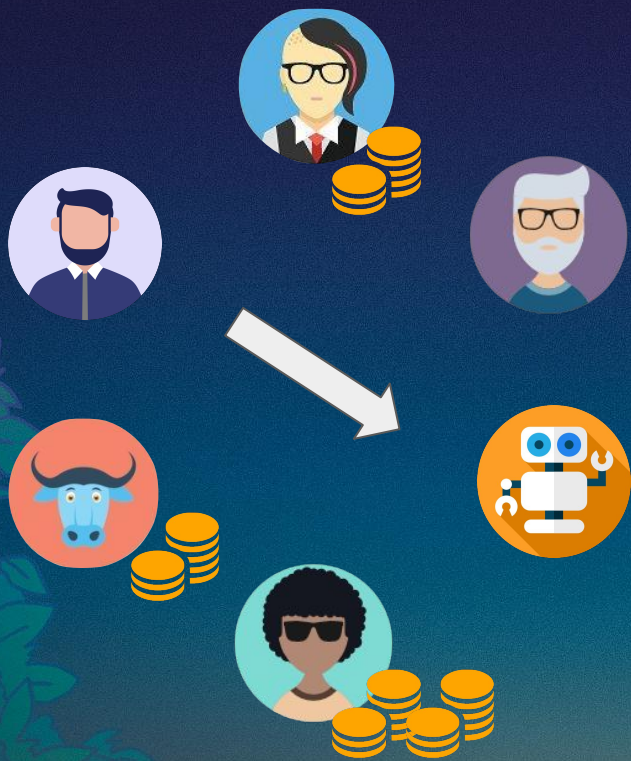

Ethereum is the first general-purpose blockchain. Smart contracts can do arbitrary computation.

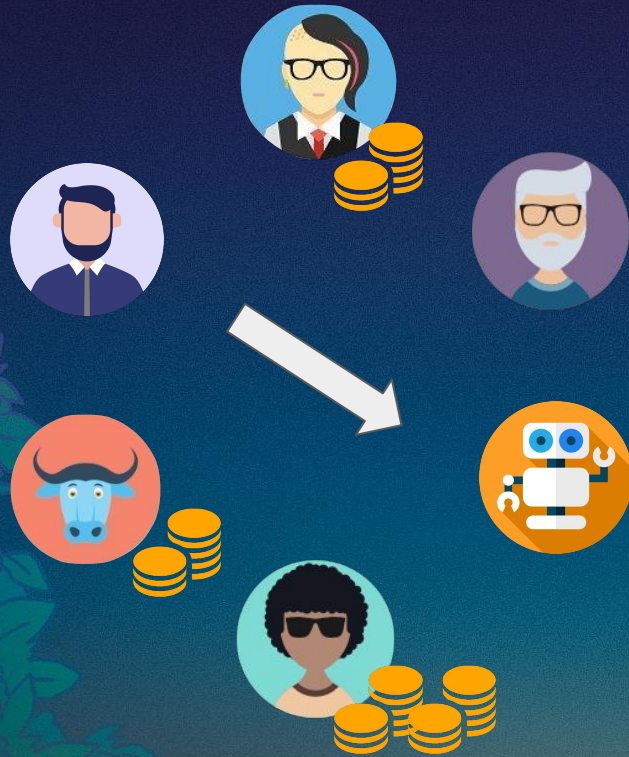

Smart contract

<address>

<balance>

<code>

<memory>

Types of Transactions



Direct Transfer of ether

- Sender
- Receiver
- \$
- Maybe some input (text saved to the blockchain)
- Signed with the private key of the sender

Types of Transactions



Types of Transactions

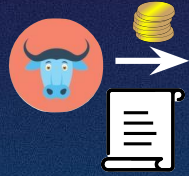

Types of Transactions

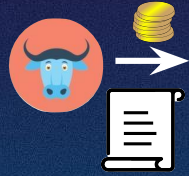

Types of Transactions

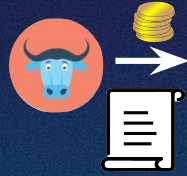

Types of Transactions

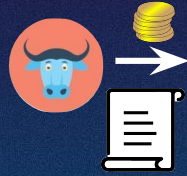

General-Purpose Computer

Ethereum allows users to build any application on it.

Using “**smart contracts**”.

Transactions can:

- Transfer tokens between accounts.
- Create new smart contracts.
- Interact with existing smart contracts.

This is the main difference with Bitcoin!

```
contract Uni {
    /// @notice EIP-20 token name for this token
    string public constant name = "Uniswap";

    /// @notice EIP-20 token symbol for this token
    string public constant symbol = "UNI";

    /// @notice EIP-20 token decimals for this token
    uint8 public constant decimals = 18;

    /// @notice Total number of tokens in circulation
    uint public totalSupply = 1_000_000_000e18; // 1 billion Uni

    /// @notice Address which may mint new tokens
    address public minter;

    /// @notice The timestamp after which minting may occur
    uint public mintingAllowedAfter;

    /// @notice Minimum time between mints
    uint32 public constant minimumTimeBetweenMints = 1 days * 365;

    /// @notice Cap on the percentage of totalSupply that can be minted at each mint
    uint8 public constant mintCap = 2;
}
```

Part of a smart contract

Types of Transactions

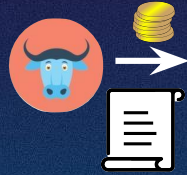

Block #22826394

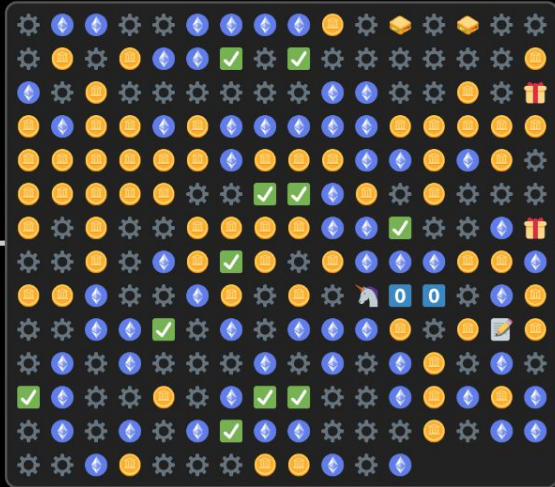

emojiblocks.com

Block #22826395



Block #22826396

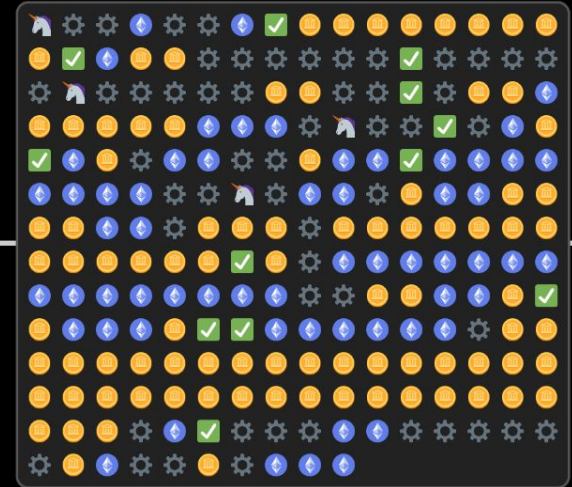



TRANSACTION ACTION

Swap 11,883.40 (\$3,314.84) SEI for 3,290.53 (\$3,289.99) USDC on Uniswap V3

Transaction Hash: [0xb91104fd5a16fd0342e9422906c92e65c52bb235ec860ff494dc9acb23ecb46b](#)

Status: Success

Block: [22827993](#) 4 Block Confirmations

Timestamp: 54 secs ago (Jul-02-2025 12:34:23 AM UTC) | Confirmed within 3 secs

Sponsored:



From: [0x5362B0A7306c6D1362b0a4DB6cb9293924050015](#)

Interacted With (To): [0x68b3465833fb72A70ecDF485E0e4C7bD8665Fc45](#) (Uniswap V3: Router 2)

ERC-20 Tokens Transferred: 2

All Transfers Net Transfers

From [Uniswap V3: USDC-SEI](#) To [0x5362B0A7...924050015](#) For 3,290.526796 (\$3,289.99) USDC (USDC)

From [0x5362B0A7...924050015](#) To [Uniswap V3: USDC-SEI](#) For 11,883.4 (\$3,314.84) SEI (SEI)

Value: 0 ETH (\$0.00)

Transaction Fee: 0.000080079931548072 ETH (\$0.19)

Gas Price: 0.681090797 Gwei (0.0000000000681090797 ETH)

Section 4

Incentives



What is Protocol Design?

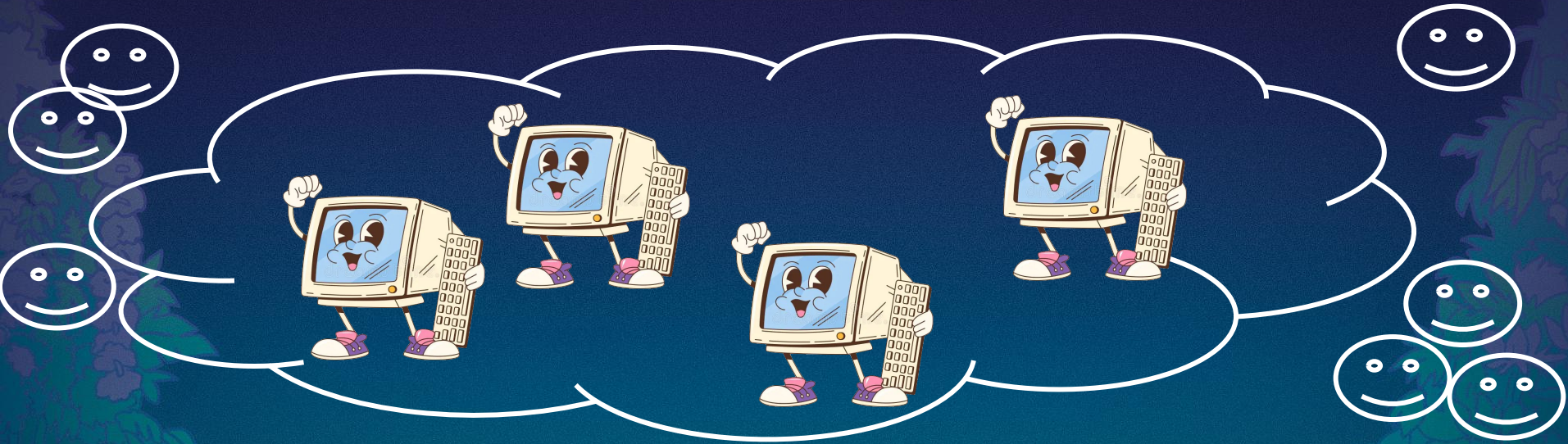

- The **Ethereum Protocol** is the **rules** that govern how users and service providers interact with the system.
- **Protocol design is about creating, updating and incentivizing these rules to obtain the ecosystem's objectives.**
 - Allowing more users to do more stuff on the *world computer* for lower fees.

Incentives, Incentives, Incentives

Ethereum is a distributed system, with incentives

- System can be maintained by anyone: Incentives for consensus participants to do their job well, under open and dynamic participation => Proof-of-Stake
- System can be used by anyone: Deal with congestion and prevent spam/DoS => Fee market
- System secures more than itself: Understand its place within a larger ecosystem => Rollups / Layer 2

txcity.io/v/eth-btc

The screenshot displays the txcity.io interface for comparing Ethereum and Bitcoin transactions. The interface is divided into three main vertical sections: a left sidebar, a central Ethereum section, and a right Bitcoin section.

- Left Sidebar:** Contains navigation icons, a 'START' button with a cartoon character, and a vertical list of levels (LEVEL 1 to LEVEL 4) with associated progress bars.
- Central Ethereum Section:** Titled 'Ethereum', it shows 'PENDING TXS 75,000+' and a 'Contribute Here!' button. A large, dense cluster of colorful cartoon avatars is positioned in the center of the road.
- Right Bitcoin Section:** Titled 'Bitcoin', it shows 'PENDING TXS 8,434' and a 'Contribute Here!' button. A large, dense cluster of colorful cartoon avatars is positioned in the center of the road.
- Transaction Lists:** Between the Ethereum and Bitcoin sections, there are two columns of transaction cards. The left column lists four Ethereum transactions, each with a hash (e.g., #22826290), amount (e.g., 2 Gwei), and fee (e.g., +0 Wei). The right column lists two Bitcoin transactions, each with an ID (e.g., #903565) and amount (e.g., Sat/v8).













payload.de/data



Crypto Fees

There's tons of crypto projects.
Which ones are people actually paying to use?

[Share](#) [Bundle](#) [Filters](#) [Yesterday](#)

Name	▼ 1 Day Fees	7 Day Avg. Fees
 Ethereum	\$5,395,335.87	\$6,738,468.55 ▼
 Bitcoin	\$2,351,199.21	\$2,576,309.72 ▼
 Uniswap	\$1,501,780.87	\$2,305,058.16 ▼
 Aave	\$1,057,274.84	\$1,062,566.66 ▼
 BNB Smart Chain	\$348,992.59	\$393,120.78 ▼
 MakerDAO	\$256,841.87	\$262,029.52 ▼
 Kyberswap	\$226,324.50	\$297,334.26 ▼
 SushiSwap	\$45,628.20	\$51,535.29 ▼
 Curve	\$34,511.50	\$47,008.70 ▼
 Arbitrum One	\$29,267.61	\$25,945.96 ▼
 Optimism	\$23,427.19	\$41,533.41 ▼
 Polygon	\$16,261.05	\$19,774.56 ▼

How much money do users spend to transact on blockchains?

<https://cryptofees.info/>

Robust Incentives Group

Ethereum Foundation research team focused on everything with strategic flavour.

Strategic in the sense:

- Stakeholders make decisions to optimise their payoffs
- Their payoffs are affected by decisions of other stakeholders

You can find their work on <https://rig.ethereum.org>



Section 5

Layer-2s



Protocol Overview

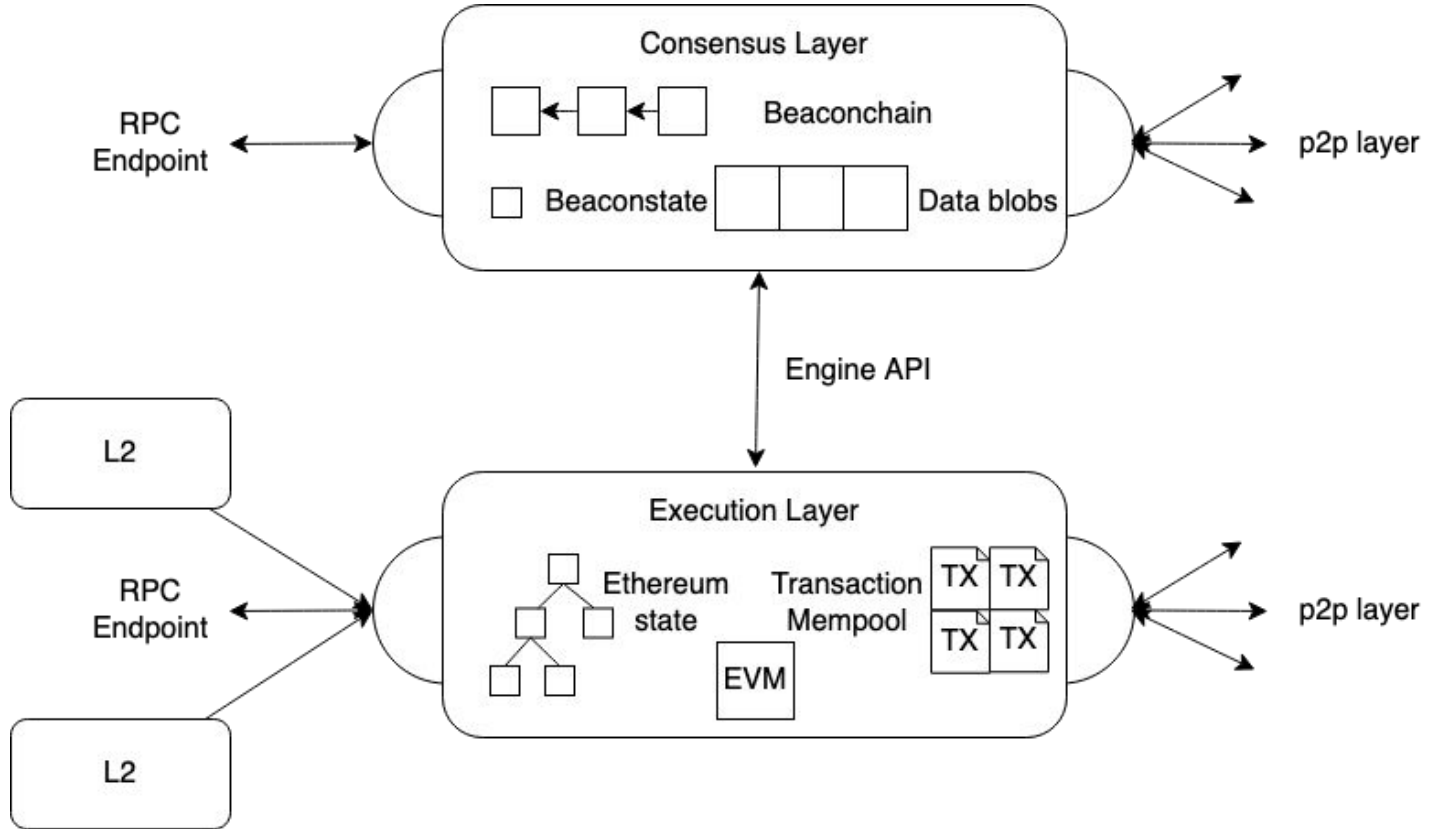

Rollups

Blobs

Totals

TPS 353.90
(30.25x)Mgas/s 86.13
(87.00x)KB/s 221.92
(42.51x)

Filters

Expand































Network	Block	TPS	Mgas/s	KB/s	Stack	DA	Settlement
Base	32303667	119.1	26.28	70.71	op-stack	blobs	ethereum
Molten Network	50433232	59.5	1.85	21.99	arb-nitro	anytrust	arbitrum
ArbitrumOne	353218695	40.0	7.15	16.66	arb-nitro	blobs	ethereum
Polygon PoS	73456895	39.9	9.48	30.15	polygon-pos	-	ethereum
Unichain	20648324	23.0	4.42	14.12	op-stack	blobs	ethereum
OP Mainnet	137898953	17.0	10.95	20.44	op-stack	blobs	ethereum
Ethereum	22826355	11.7	0.99	5.22	ethereum	ethereum	ethereum
Gravitiy	74882467	6.2	0.36	3.43	arb-nitro	celestia	ethereum
WINR	59581905	5.4	2.11	4.42	arb-nitro	celestia	arbitrum
ProofOfPlay - Boss	91022216	5.3	3.44	3.84	arb-nitro	anytrust	arbitrum
Blast	21293434	5.3	3.26	1.45	op-stack	blobs	ethereum
Abstract	13226440	5.0	0.98	0.00	zksync	blobs	ethereum
Ink	17898273	4.3	4.79	1.63	op-stack	blobs	ethereum
Plume	9155806	3.2	0.42	1.96	arb-nitro	celestia	ethereum
Mantle	81633186	2.4	0.33	1.41	op-stack	mantle	ethereum
Xchain	5627237	2.4	0.61	4.15	arb-nitro	anytrust	ethereum
Mode	25614550	2.3	2.20	0.91	op-stack	blobs	ethereum
Redstone	19605796	2.3	0.99	3.50	op-stack	plasma	ethereum
ProofOfPlay - Apex	129842637	2.1	1.28	1.51	arb-nitro	anytrust	arbitrum
Xai	102818831	1.3	0.08	0.50	arb-nitro	anytrust	arbitrum
Linea	20495159	1.1	0.19	0.66	linea	blobs	ethereum
Metis	20755165	1.1	0.22	2.30	metis	metis	ethereum
Katana	4653873	1.1	2.29	1.12	agglayer-cdk	blobs	ethereum
Pepe Unchained	9132022	1.0	0.08	0.52	op-stack	celestia	ethereum
zkSync Era	62377547	0.8	0.12	0.00	zksync	blobs	ethereum
ApeChain	18854338	0.7	0.05	0.79	arb-nitro	anytrust	arbitrum
Scroll	16895732	0.5	0.10	0.45	scroll	blobs	ethereum
Lisk	18333945	0.4	0.26	0.56	op-stack	blobs	ethereum
Fraxtal	22292986	0.2	0.76	0.97	op-stack	blobs	ethereum
Rari	3134528	0.2	0.01	0.13	arb-nitro	anytrust	arbitrum

Dashboard: Rollup.wtf

<https://rollup.wtf/>

Rollups 24 Validiums & Optimiums 3 Others 107

Rollups are L2s that periodically post state commitments to Ethereum. These commitments are validated by either Validity Proof mechanism within a certain fraud proof window. Additionally L2 data is also posted to Ethereum, hence there are no additional data requirements.

#	NAME	RISKS	TYPE	STAGE
1	 Arbitrum One		Optimistic Rollup 	STAGE 1
2	 Base		Optimistic Rollup 	STAGE 1 
3	 OP Mainnet		Optimistic Rollup 	STAGE 1 
4	 Unichain		Optimistic Rollup 	STAGE 1 
5	 ZKsync Era		ZK Rollup 	STAGE 0
6	 Starknet		ZK Rollup 	STAGE 1
7	 Linea		ZK Rollup	STAGE 0
8	 Scroll		ZK Rollup	STAGE 1 
9	 Ink		Optimistic Rollup 	STAGE 1 

Dashboard: L2 Beat

<https://l2beat.com>

emojiblocks.com

Block #22826394

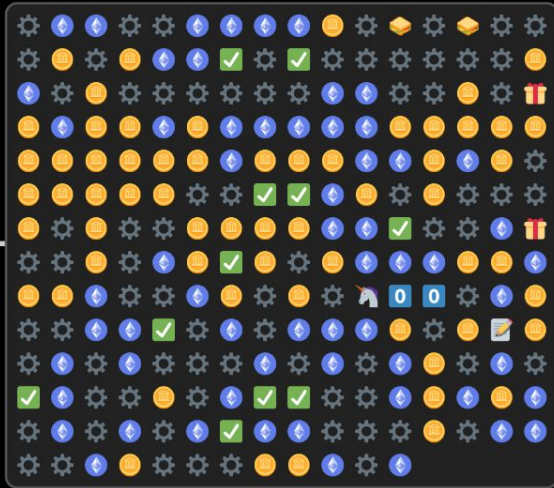

Block #22826395



Block #22826396

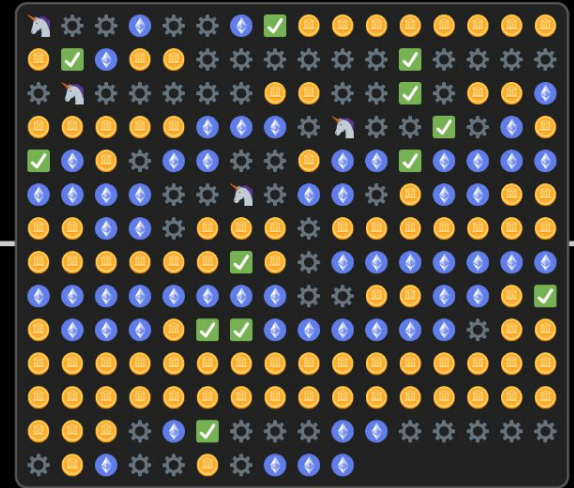

Section 6

Decision Making & Governance



Distributed Decision Making

- No single party can decide what happens to Ethereum.
- Ethereum researchers free to work on the topic they believe to be most impactful.
- Different people prefer different Ethereum futures.

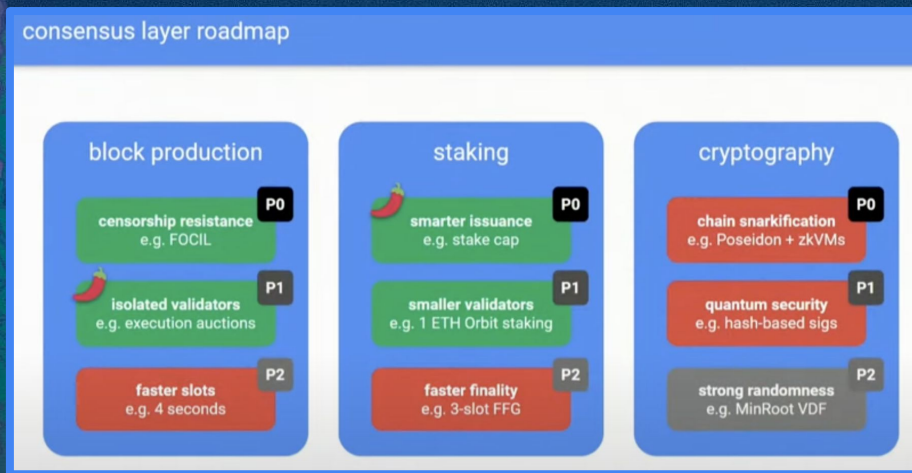

Justin Drake's beamchain

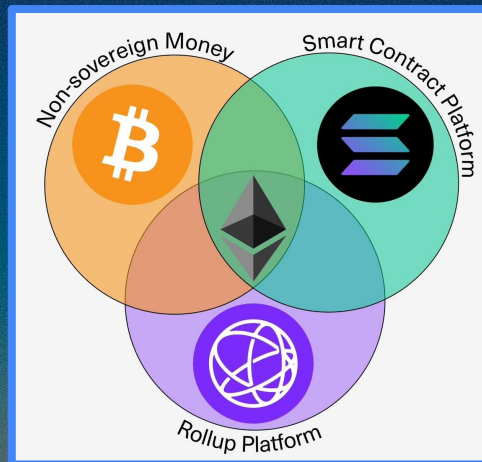

Jon Charbonneau's View

So, you want to improve Ethereum









Time



1. Find what Ethereum is currently lacking.
 - a. DA, Execution, Settlement, others?
2. Contribute to developing ideas.
 - a. Inclusion Lists developed by multiple people over time.
 - b. Many parallel research streams.
 - c. New streams popping up!
3. Research to production.
 - a. Out-of-protocol data gathering.
 - b. Prototypes, testnets, etc.
4. Propose Ethereum Improvement Proposal (EIP).
5. Convince the community!

All Core Devs

Recording

stokes stokes	Tim Beiko Tim Beiko	Andrew Ashi... Andrew Ashikhmin	Mikhail Kalinin Mikhail Kalinin	Martin Holst... Martin Holst Swende	Greg Colvin Greg Colvin
Marek Morac... Marek Moraczyński	Vadim Arasev Vadim Arasev	 Justin Florentine	Marcin Sobcz... Marcin Sobczak	Micah Zoltu Micah Zoltu	Jose 's iPhone Jose 's iPhone
protolambda protolambda	lightclient lightclient	HP HP	 Danno Ferrin	terence(prys... terence(prysmaticlabs)	Jamie Lokier Jamie Lokier
Ansgar Dietri... Ansgar Dietrichs	Kevaundray... Kevaundray Wedderb...	 Matt Nelson	carlbeek carlbeek	Druthers Druthers	Karim T. Karim T.
Fabio Di Fabio Fabio Di Fabio	Rim Rakhimov Rim Rakhimov	 Phil Ngo	yuga yuga	 SasaWebUp	 Ben Edgington
 Sam Wilson	 Lukasz Rozmej	Paweł Bylica Paweł Bylica	Dankrad Feist Dankrad Feist	 Gary Schulte	Rai Rai

Participants (36)

Search

- TB Tim Beiko (me)
- AA Andrew Ashikhmin
- AD Ansgar Dietrichs
- Ben Edgington
- c carlbeek
- Dankrad Feist

Invite Mute Me Claim Host

Chat

Martin Holst Swende to Everyone 7:43 AM
are all EL-testnets 'paired' with a CL testnet already?

Gary Schulte to Everyone 7:43 AM
Just goerli has a long lived CL testate afaik

*testnet

Who can see your messages? Recording On

To: Everyone

Type message here...

Hardforks

- About every year, new Ethereum update.
- Accepted EIPs introduced via a **hardfork**.
 - New set of protocol rules that govern how honest actors behave.
- Hardforks require:
 - All core devs incorporating the software into multiple clients.
 - Testing of the upgrades.
 - Validators adopting new upgrade.

Section 7

What's Next For Ethereum?



Announcing Protocol

Posted by Barnabé Monnot, Tim Beiko, Alex Stokes on June 2, 2025

Organizational

1. **Scale L1**
2. **Scale L2**
3. **Improve UX**



EIP Example: Block Construction

- One actor per slot has full control over **inclusion, ordering, and exclusion** of transactions.
- Ethereum protocol elects one proposer to facilitate an auction choosing the builder.
- Sensitive to censorship for economic or regulatory reasons.

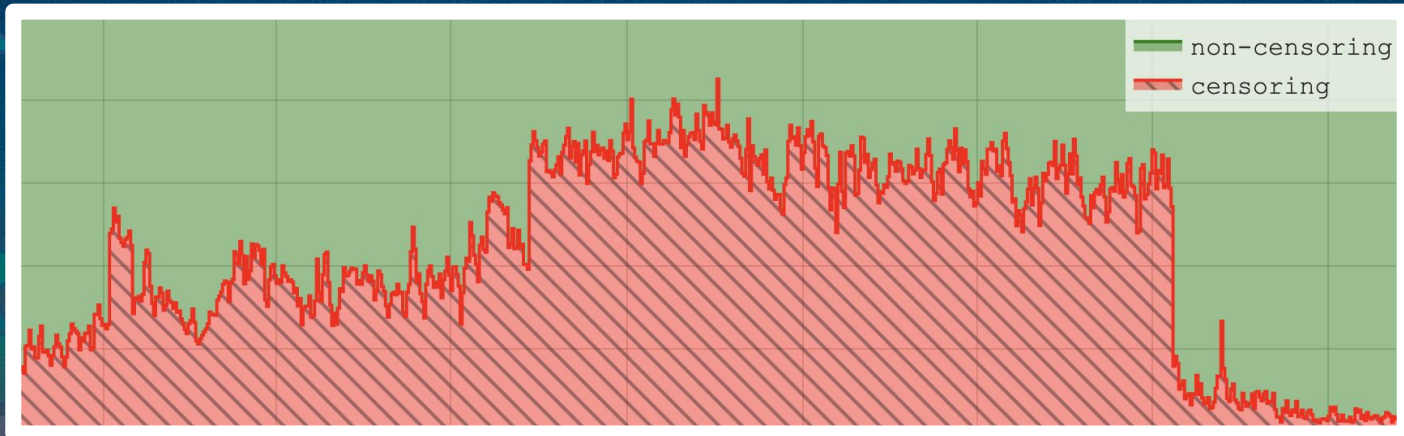

Inclusion Lists

- Family of designs that allow multiple people to include transactions in a block.
- **Chain neutrality:** Any pending, fee-paying transaction ought to be included if it is available and if there is room to include it on-chain.

